

Overview

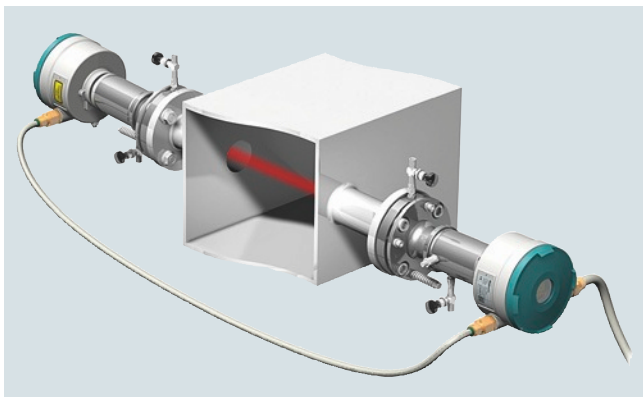

SITRANS SL

SITRANS SL is a diode laser gas analyzer with a measuring principle based on the specific light absorption of different gas components. SITRANS SL is suitable for fast, non-contact measurement of gas concentrations in process or flue gases. An analyzer consisting of transmitter and receiver units (sensors) is used for each measuring point. The hardware for further processing of the measured signal into a concentration value, as well as the monitoring, control and communication functions, are integrated in these two main modules. The sensors are designed for operation under harsh environmental conditions.

Benefits

The in-situ SITRANS SL gas analyzer features high operational availability, unique analytical selectivity, and a wide range of possible applications. SITRANS SL permits measurement of a gas component directly in the process:

- With high dust load
- In hot, humid, corrosive, explosive, or toxic gases
- In applications showing strong varying gas compositions
- Under harsh environmental conditions at the measuring point
- Highly selective, i.e. mostly without cross-sensitivities

Special features of the SITRANS SL:

- Little installation effort
- Minimum maintenance requirements
- Extremely rugged design
- High long-term stability through built-in, maintenance-free reference gas cell
- Real-time measurements

Moreover, the analyzer provides warning and error messages:

- When maintenance is required
 - With large variations in the reference signal
 - With poor signal quality
- If the transmission violates an upper or lower limit

Application

Applications

- Control of combustion processes
- Process optimization
- Plant and operator safety
- Process measurements in all types of power and combustion plants
- Process control
- Explosion protection
- Measurements in corrosive and toxic gases
- Quality control

Sectors

- Chemical and petrochemical plants
- Power plants
- Waste incinerators
- Iron and steel industry

In situ continuous process gas analysis

SITRANS SL

In situ O₂ gas analyzer

Design

The SITRANS SL gas analyzer consists of a pair of cross-duct sensors, a transmitter unit and a detector unit, both with the same dimensions. The complete analyzer is integrated in these two enclosures. The transmitter unit contains the laser source whose light is transmitted to the receiver through the measurement path. The detector unit contains a photodetector including electronics as well as a reference cell. The detector unit is connected to the transmitter unit by means of a sensor cable. A further cable on the receiver is used to connect the power supply and the communication interfaces. The receiver enclosure contains a local user interface (LUI) with an LC display which can be read through a window in the cover. The LUI is operated by remote-control.

Transmitter and detector units

Special features of the transmitter and detector units:

- In-situ cross-duct sensors, designed as transmitter and detector units, connected via sensor cable
- Powder-coated aluminium; stainless steel
- Degree of protection IP65
- Adjustable process connection plates
- Flange sizes (provided by customer): DN50/PN25, ANSI 4"/150 lbs
- Purging gas connections (see "Purging")
- Optional: Explosion-protected version in accordance with
 - Ex II 2G Ex de op is IIC T6
 - Ex II 2D Ex tD A21 IP65 T85°C

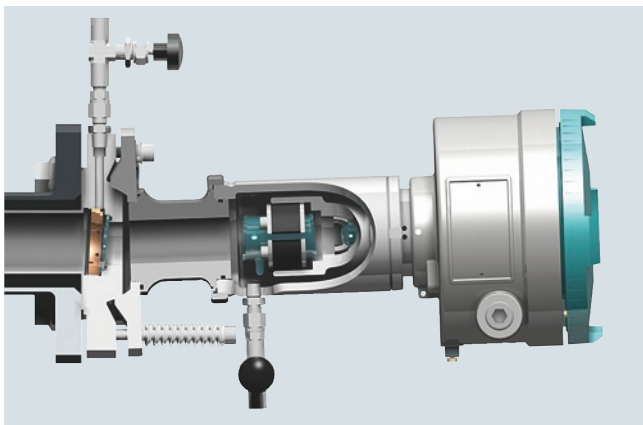

SITRANS SL, detector unit

Parts in contact with the process gas

Only the stainless steel flange of the sensor with borosilicate window and FFKM seal comes in contact with the process gas. This has optional connections for purging the process gas side with an appropriate gaseous medium.

Display and control panel

Special features of the detector unit:

- Display for simultaneous output of result and device status
- LED backlighting of display
- Remote control with infrared interface for simplified configuration and operation for safe implementation in hazardous areas
- Menu-driven operation for parameterization and diagnostics



Local user interface (LUI) of SITRANS SL in the detector unit (display of measured value)

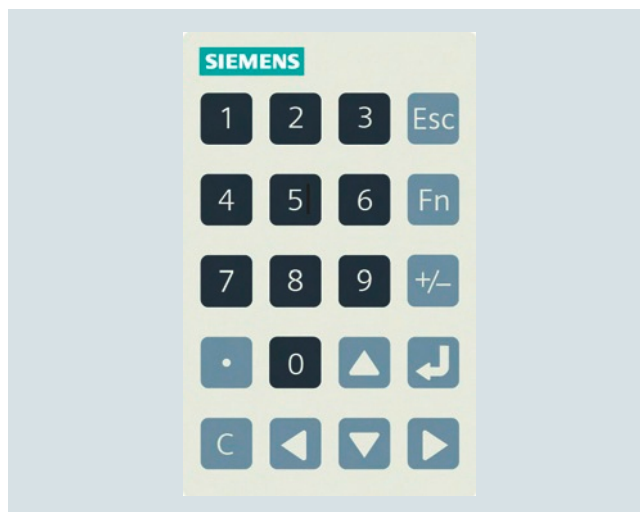

Remote control keypad for SITRANS SL

Connection cables

SITRANS SL is supplied as standard without connecting cables. These must be provided by the customer or are available as accessories. Exception: The standard ATEX version is supplied with pre-installed cabling.

The sensor cable connects together the transmitter and detector units of the analyzer.

The sensor connecting cable available as a cable set for the ATEX version as standard, and for non-Ex applications optionally, is offered in lengths of 5, 10 or 25 m. This (optional) cable set also enables permanent installation of an Ethernet cable used for service and maintenance purposes.

A rugged cable sleeve should be used as UV protection for installations in open cable ducts or channel systems.

The statutory directives must be observed in the event of installation in hazardous areas.

For the ATEX version of SITRANS SL, the sensor connecting cable must be connected between the two Ex-e terminal boxes secured on the transmitter and receiver units.

Inputs/outputs

- 2 analog inputs (4 to 20 mA) for process gas temperature and pressure
- 2 analog outputs (4 to 20 mA) for gas concentration or for concentration and transmission
- 1 configurable digital input
- 2 configurable digital outputs (display of faults, maintenance requirement, function monitoring, alarms for limit violations of measured value or transmission)
- 1 Ethernet 10Base-TX port, only for servicing and maintenance

Optional

- 1 Modbus interface with
 - Output of concentration as cyclic data
 - Alarm output, alarm classification
 - Input for temperature and/or pressure data for compensation
- 1 PROFIBUS DP interface with:
 - Output of concentration as cyclic data
 - Alarm output, alarm classification
 - Input for temperature and/or pressure data for compensation

The PROFIBUS DP protocol provides DPV0, cyclic data. Measured values are provided with additional quality data.

Note:

In contrast to the other interfaces, the Ethernet plug-in connector on standard non-Ex devices is only accessible following removal of the detector unit cover. With the help of the sensor cable set (optional with non-Ex devices), an Ethernet cable can be permanently installed via the terminal box of the sensor connecting cable. The Ethernet connection via the sensor cable can also only be used for temporary service and maintenance purposes.

NOTICE:

In an Ex environment, Ethernet connections may only be made or removed with the permission of the plant operator!

Function

Operating principle

SITRANS SL is a gas analyzer employing single-line molecular absorption spectroscopy. A diode laser emits a beam of infrared light which passes through the process gas and is received by a detector unit. The wavelength of the laser diode output is tuned

to a gas-specific absorption line. The laser continuously scans this single absorption line with a very high spectral resolution. The degree of absorption and the line shape are used for the evaluation.

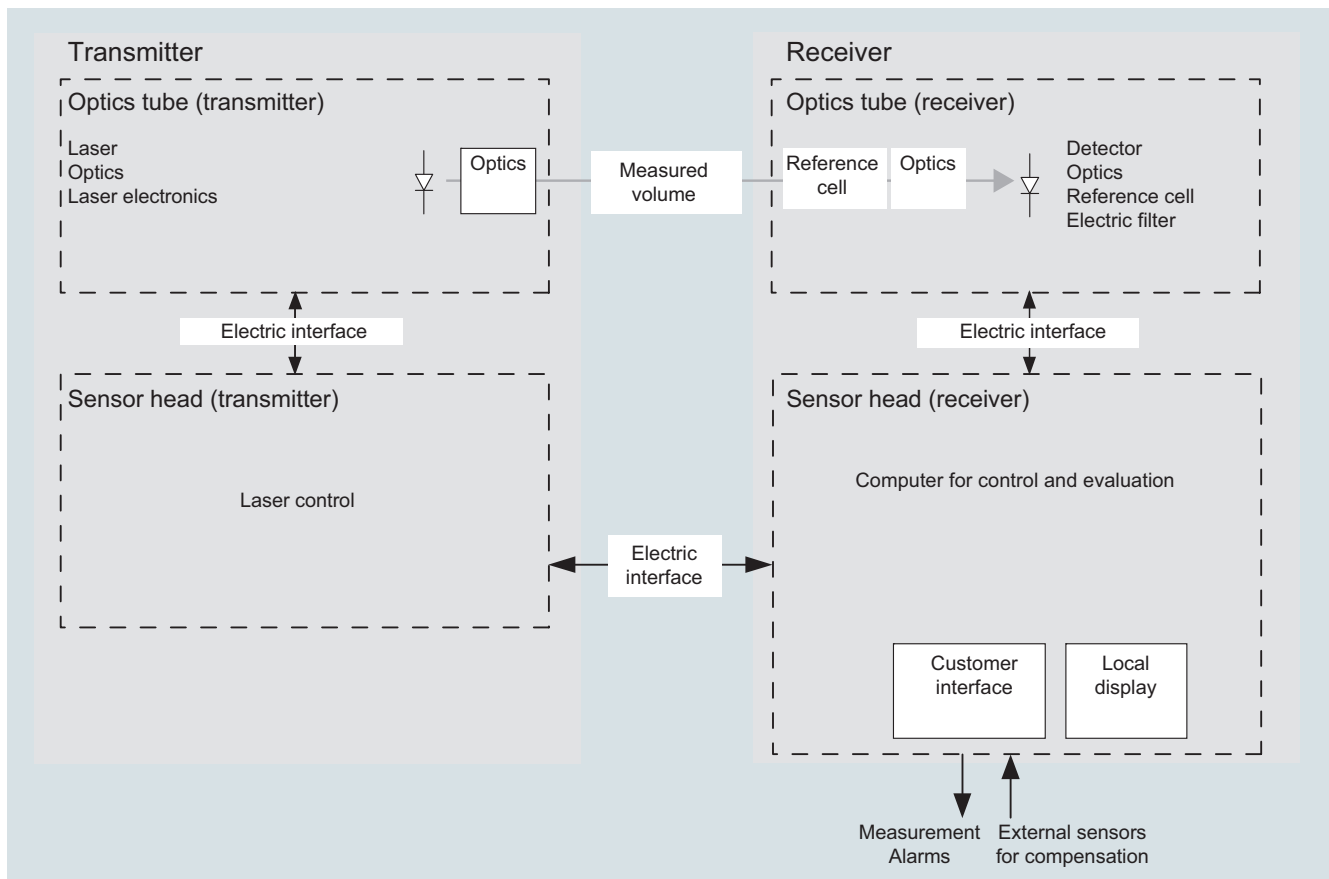

Basic design of the SITRANS SL

In situ continuous process gas analysis SITRANS SL

In situ O₂ gas analyzer

The field design of the SITRANS SL in-situ gas analyzer consists of a transmitter unit and a detector unit. The light which is not absorbed by the sample is detected in the receiver. The concentration of the gas component is determined from the absorption.

The SITRANS SL analyzer measures a single gas component by means of the absorption capacity of a single fully resolved molecular absorption line.

2

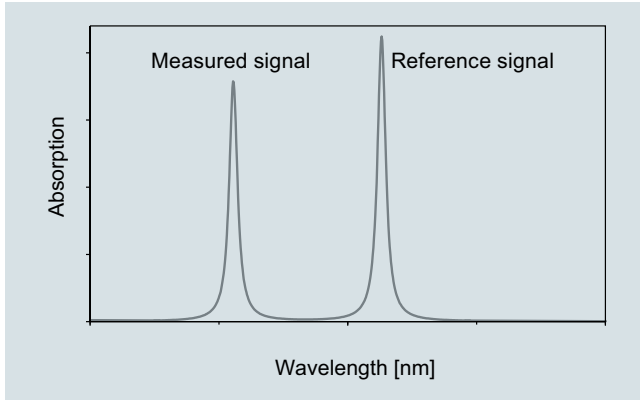

Absorption spectrum of measured signal and reference signal with SITRANS SL

SITRANS SL is designed for measuring oxygen (O₂) with high sensitivity.

Typical application specifications:

| | |
|---|--|
| Oxygen concentration | 0 ... 100 vol % |
| Process pressure/temperature conditions (with O ₂ application) | 700 ... 5 000 hPa (absolute)/ 0 ... 200 °C 900 ... 1 100 hPa (absolute)/ 0 ... 600 °C |

The measuring performance of the SITRANS SL depends, among others, on the actual, individual process conditions with regard to concentration ranges, pressure and temperature.

An internal reference cell is used to constantly check the stability of the spectrometer.

The self-calibration of the analyzer is therefore valid for one year without the need for external recalibration using calibration gases.

Configuration

A feature of the in-situ analytical procedure is that the physical measurement takes place directly in the stream of process gas and directly in the actual process gas line. All process parameters such as gas matrix, pressure, temperature, moisture, dust load, flow velocity and mounting orientation can influence the measuring properties of the SITRANS SL and must therefore be investigated for each new application.

The standard applications listed in the ordering data for the SITRANS SL are distinguished in that the typical process conditions are adequately well-known and documented. If you cannot find your application among the standard applications, please contact Siemens. We will be pleased to check your possible individual application of the SITRANS SL. You can find an application questionnaire on the website for the SITRANS SL:
<http://www.siemens.com/insituquestionnaire>

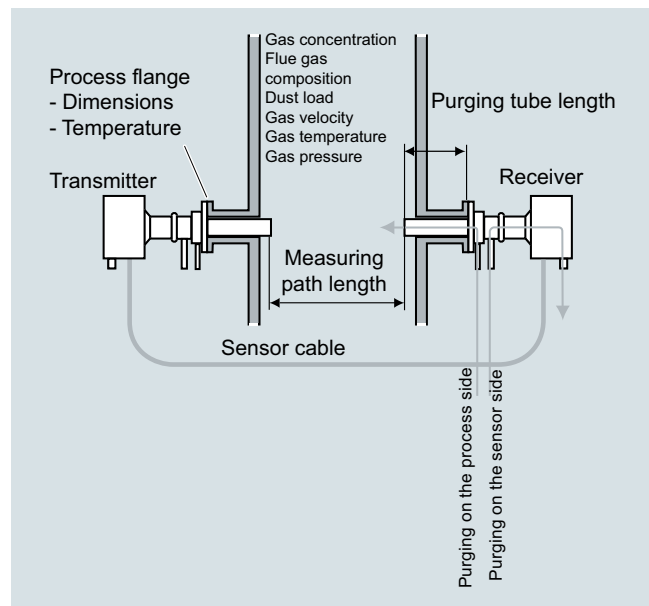

Typical cross-duct arrangement of the SITRANS SL

The SITRANS SL can be optionally purged on the process side using appropriate purging gases to prevent contamination of the sensor optics on the process side. Purging tubes on the sensor heads, which slightly extend into the process gas stream, define the effective measuring path length.

Influences on the measurement

Dust load

As long as the laser beam is able to generate a suitable detector signal, the dust load in the process gas does not influence the analytical result. By applying a dynamic background correction, measurements can be carried out without any negative impact. Under optimal conditions, the SITRANS SL can cope with dust loads up to 20 g/Nm³ and up to a measured path length of 8 m. The influence of a high dust load is extremely complex, and depends on the optical path length and particle size. The optical attenuation increases exponentially at longer path lengths. Smaller particles also have a very large influence on the optical attenuation. With high dust load, long path length and small particle size, the technical support at Siemens should be consulted.

Temperature

The influence of temperature on the absorption line is compensated by a correction file. A temperature signal can be fed into the instrument from an external temperature sensor. The signal is then used for mathematical correction of the influence of the temperature on the concentration strength. If the process gas temperature remains constant, a static correction can be carried out as an alternative. Without temperature compensation, the relative error caused by changes in the gas temperature has an extensive effect on the measurement (e.g. up to 0.24 %/K with the O₂ application). An external temperature signal is therefore recommended in most cases.

Pressure

In addition to the temperature signal, an external pressure signal can be fed to the instrument to provide complete mathematical compensation for the pressure influence including the density effect. Without compensation, the relative error caused by changes in the process gas pressure is approx. 0.1 %/hPa. An external pressure signal is therefore recommended in most cases.

Effective optical path length

As a result of Beer-Lambert's law, the absorption of laser light depends on the optical path length within the sample gas. Therefore the precision of the effective optical path length measurement can have an effect on the precision of the total measurement.

Since the sensor optics on the process side usually has to be purged to keep it clean for a longer period, the extent of the mixed zone between the purging medium and the process gas as well as the latter's concentration distribution must be considered. In a typical in-situ installation with an optical path length of several meters, the influence of the purging gas on the effective path length can be ignored.

The maximum possible path length and dust load mutually affect each other: the higher the dust load in the process, the shorter the max. possible path length.

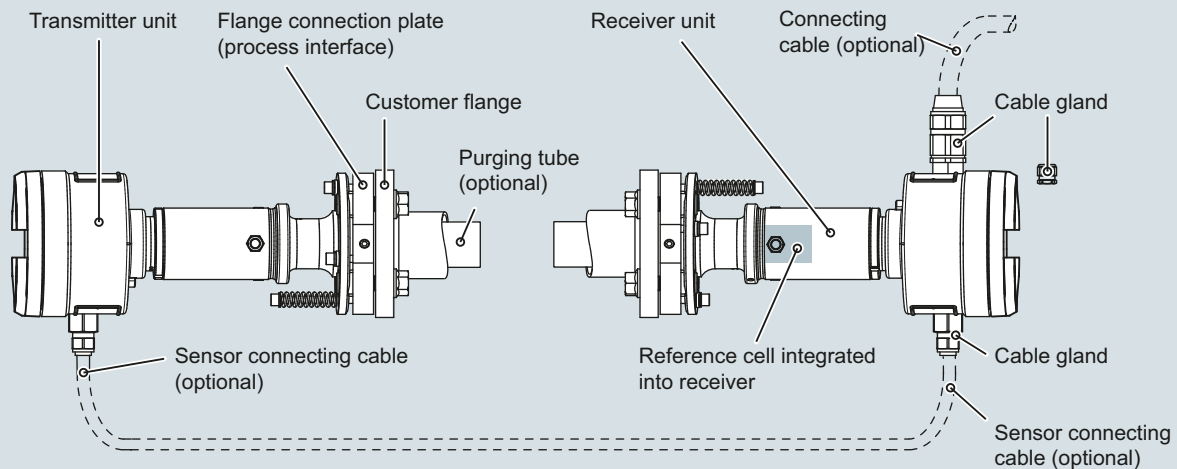

Design of the SITRANS SL system in non-Ex version

In situ continuous process gas analysis

SITRANS SL

In situ O₂ gas analyzer

2

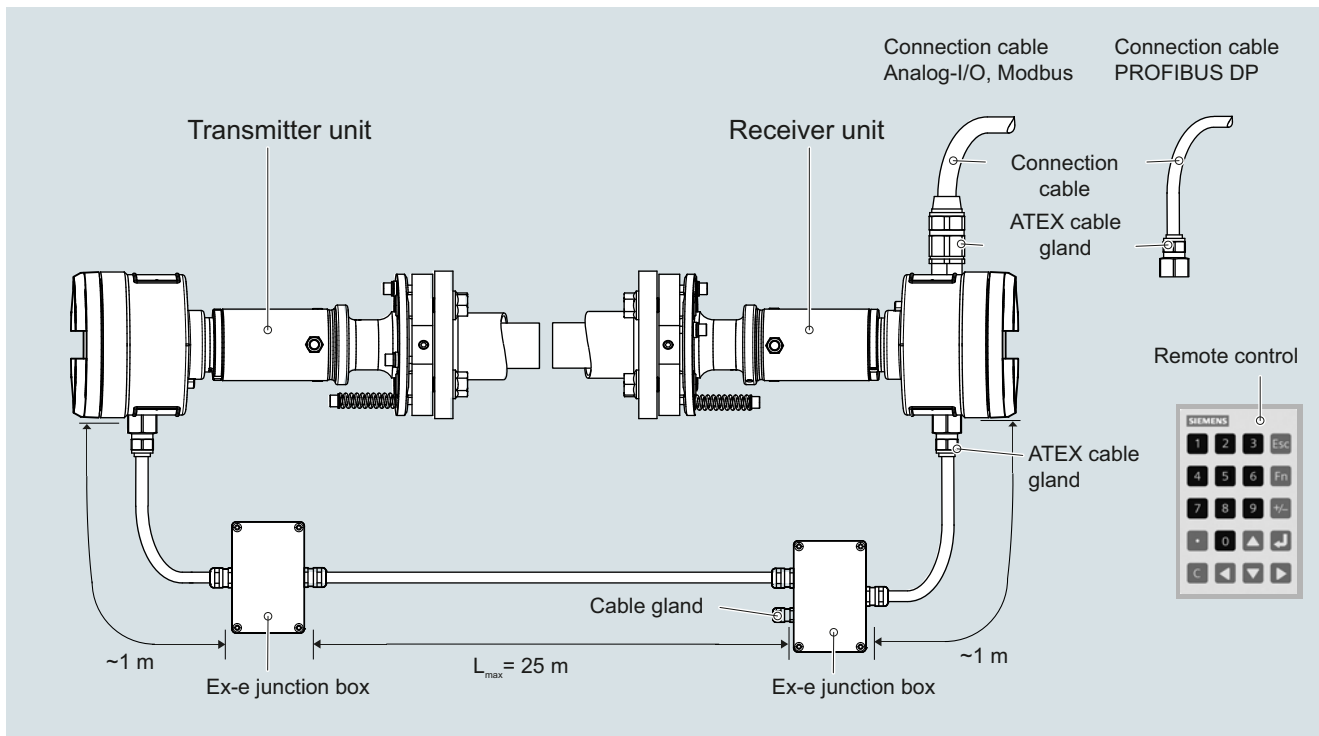

Design of the SITRANS SL system in ATEX version

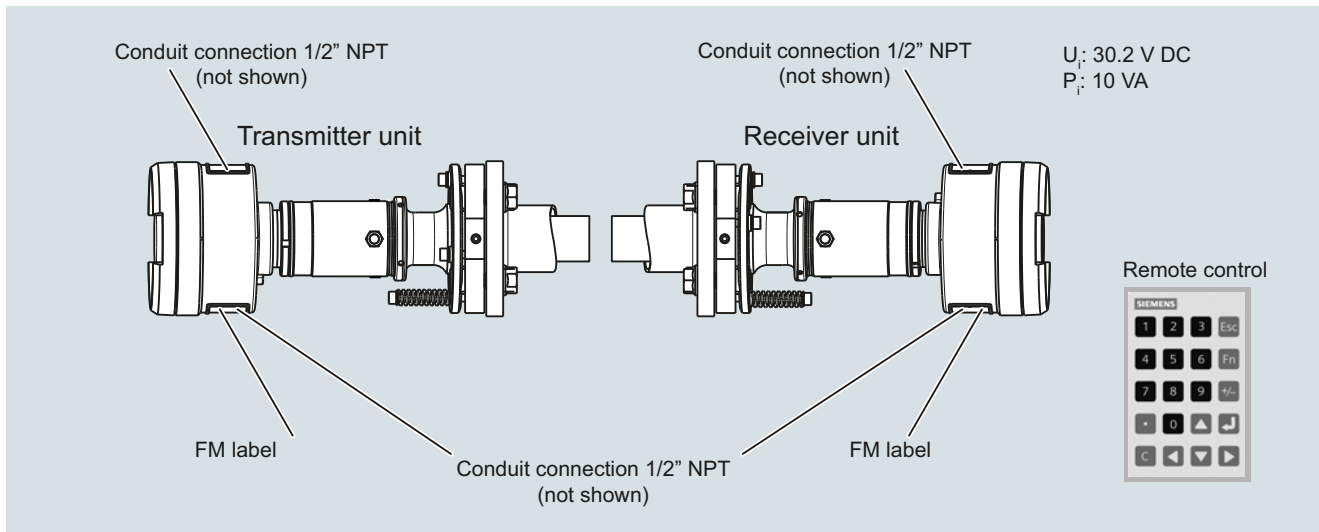

Design of the SITRANS SL system in FM version

The transmitter and detector units are mounted on process flanges provided by the customer. Correct alignment of these flanges must be guaranteed, e.g. by using the optional sensor alignment kit.

Adjustment of the pair of sensors

The flange connection plates (process interface) of the SITRANS SL to the process flanges on the customer side must be correctly aligned so that the laser beam generated by the transmitter hits the photodetector in the detector unit. This is guaranteed in that the transmitter and detector units have a curved surface integrated in the connection plates. The adjustment is carried out by shifting the flanges on these surfaces, through which the symmetry axis is aligned. The axis can be offset by ± 1 degree, which means that the process flanges must be welded onto the process wall with at least this accuracy - see following figure.

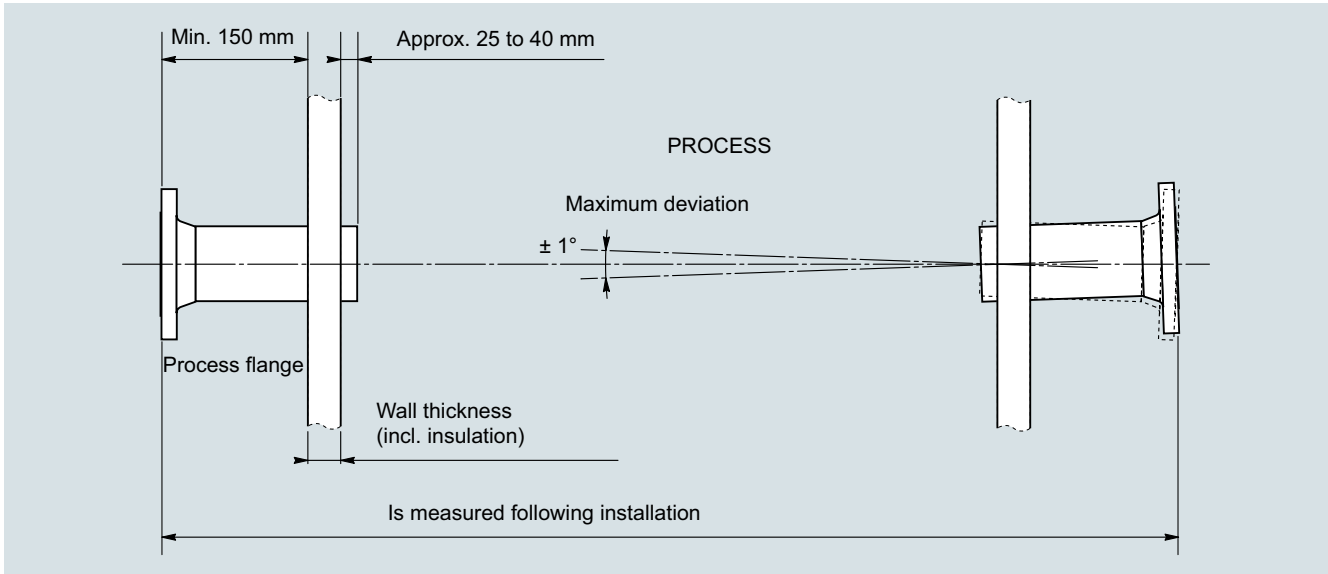

Installation/adjustment requirements for the pair of cross-duct sensors

In situ continuous process gas analysis

SITRANS SL

In situ O₂ gas analyzer

Purging

The easiest way to avoid condensation and dust deposits on the sensor windows or excessively high thermal load of the windows and the sealing material as well as the sensor electronics is to purge them (with O₂ application: nitrogen). Purging must be selected depending on the application. The transmitted-light sensors can therefore be configured for the respective situation. The application reference table provides recommendations for suitable purging for the standard applications.

If oxygen is to be measured with the SITRANS SL - which is also present in measurable quantities in the ambient air - oxygen-free purging gases must be used, such as nitrogen. It is equally necessary to purge the inside of the sensor heads, since the ambient air must also be displaced here out of the laser beam path. A differentiation is therefore made between purging on the process side and purging on the sensor side.

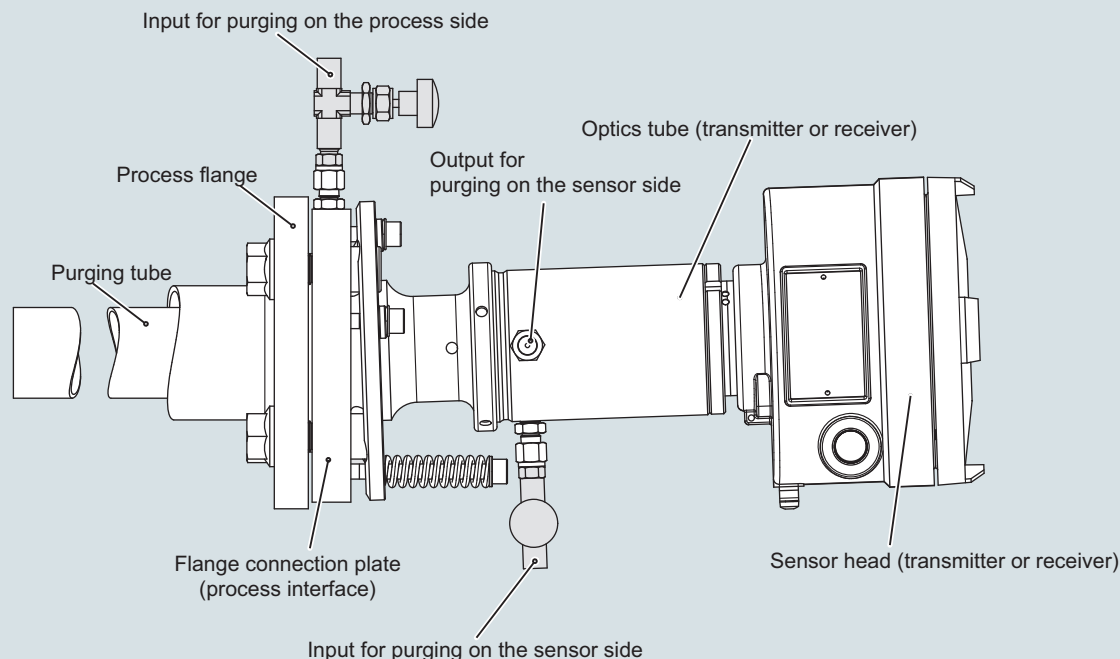

Arrangement for purging on the sensor side of the SITRANS SL

Purging on process side

For purging on the process side, the flow of purging gas can be adjusted between 0 and approx. 50 l/min at each sensor head using a needle valve (included in delivery).

Purging on sensor side

This can be combined with the purging on the process side, if required. Purging with nitrogen on the sensor side is almost always necessary for O₂ applications to avoid an offset caused by the oxygen of the air present in the unit. The cells in the sensor head are then continuously purged with nitrogen. Particularly when (re)starting the SITRANS SL O₂, a sufficiently high flow of purging gas of approx. 3 to 5 l/min must be provided for several minutes to ensure that all residues of oxygen are removed. The flow of sensor purging gas can subsequently be set to a lower value using the needle valve (included in delivery).

Note:

With purging on the process side, it may be necessary to use non-return valves to ensure no process gas can enter the purging gas line in the event of failure of the purging gas supply. This applies especially in the case of cascaded process and sensor purging where there is otherwise the danger that, for example, corrosive process gases could enter the sensor enclosure.

Purging tubes

The purging media used on the process side flow through purging tubes into the process gas stream. The tubes extend into the process area by a few centimeters, usually perpendicular to the process gas stream. This means that an exactly defined optical path length is defined through the sample gas. The effective

measuring path in the process gas is therefore defined as the distance between the ends of the two purging tubes. The standard length of the purging tubes is 340 mm. To achieve sufficient calibration of the transmitter and receiver, the process wall should be max. 150 mm thick.

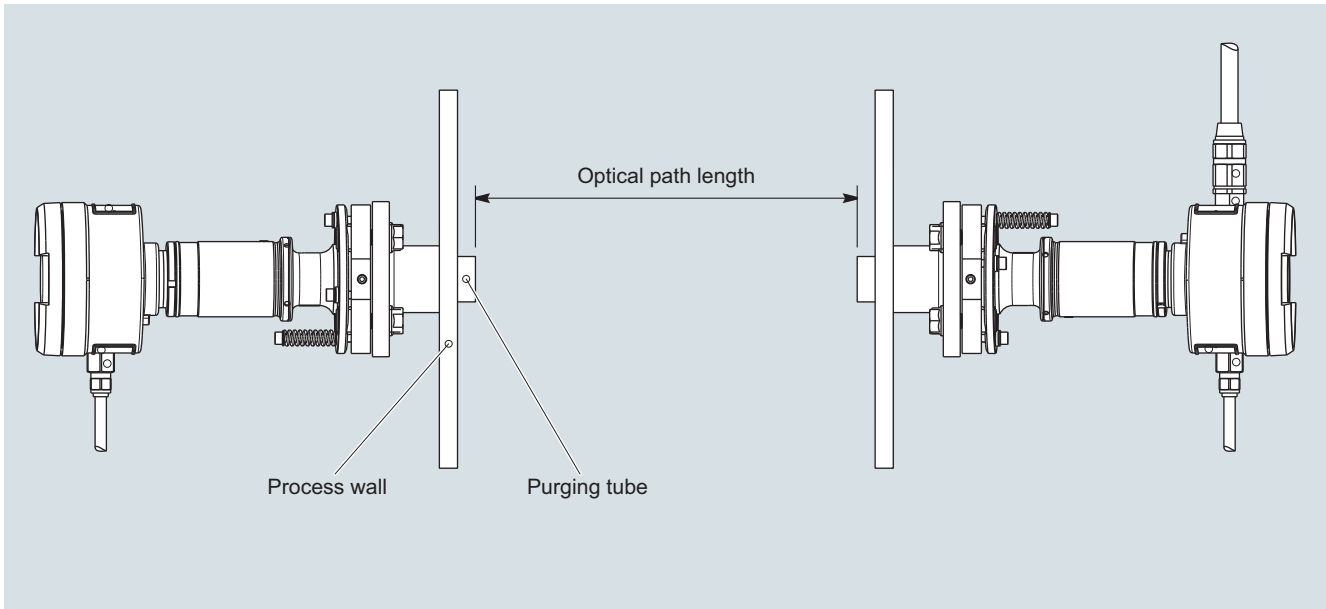

Measurement of the optical path length between the ends of the purging gas tubes

Maintenance and fault messages

The SITRANS SL carries out continuous self-monitoring, and outputs alarms and warnings to indicate maintenance requirements or a system fault. The information is output as plain text on the LUI display, where symbols identify the category and the severity of the fault.

Alarm categories:

- Maintenance (system must be cleaned or repaired)
- Process value (problem with external sensor, or process conditions outside the permissible range for SITRANS SL)
- Configuration (SITRANS SL is not correctly configured)

Severity:

- Fault (measurements could not be carried out)
- Warning (measurements may be inaccurate, or the system will soon shut down measuring mode if an intervention is not made)
- Advanced warning/information (measurements are carried out)

The two binary (relay) outputs can be configured freely for the alarm output.

The response of the analog outputs in the event of an alarm is configurable; possible actions are:

- Off (current measured value is displayed)
- Last measured value (freezing of last value displayed)
- Standard level (setting to predefined value)
- 3 mA (NAMUR NE43 fault status)

In addition, the transmission is available as an output variable.

Note

Specific requirements for the measuring point can make the utilization of special sensor equipment necessary. The possibilities for adapting the sensors are:

- Special materials for purging tubes (on request)
- Various types/sizes of sensor flanges
- Explosion-protected sensor configurations

Essential characteristics

- Long-term stabilization by using an internal reference cell; for calibration interval of at least one year
- Dynamic background correction for varying dust loads
- Isolated signal outputs of 4 to 20 mA
- User-friendly, menu-driven operation
- Selectable time constants (response time)
- Password-protected user interface
- I/O operation in accordance with NAMUR recommendations
- Monitoring of overall optical transmission
- Sensor enclosure resistant to wear and corrosion
- Simple local operation using remote-control unit with numeric keypad and menu prompting

In situ continuous process gas analysis

SITRANS SL

In situ O2 gas analyzer

Standard applications

The following table lists the measuring conditions for standard applications. The listed values for the measuring range and detection limit are only approximate values. The exact values at the respective measuring point depend on the totality of all influencing variables and can be determined by Siemens for the specific

case. Note that the values for the detection limit and the maximum measuring range are based on a path length of 1 m. Longer path lengths will improve the detection limit, but not linearly. This is due to limiting effects such as dust load. The maximum applicable measuring ranges can only be used if permitted by the process conditions such as dust load.

2

| Standard application | | | Process gas temperature $T_{min} \dots T_{max}$ | Process gas pressure $p_{min} \dots p_{max}$ | Min. measuring range (with 1 m eff. opt. path length) | Max. measuring range (also dependent on eff. opt. path length: see following column) | Max. measuring range x path length | DL x path length (under standard conditions ¹⁾ without cross-interference of other gases) | Repeat-ability ³⁾ | Purging gas medium |
|---|--|------------|--|---|--|--|------------------------------------|--|------------------------------|--------------------|
| Effective optical path length: 0.3 ... 8 m | Dust load ²⁾ : < 50 g/Nm ³ | | | | | | | | | |
| Sample gas component | Gas code | Appl. code | | | | | | | | |
| O ₂ | A | B | 0 ... 600 °C | 900 ... 1 100 hPa | 0 ... 1 vol% | 0 ... 100 vol% | 75 vol%*m | 200 ppmv*m | 2% | N ₂ |
| O ₂ | A | C | 0 ... 200 °C | 700 ... 5 000 hPa | 0 ... 1 vol% | 0 ... 100 vol% | 75 vol%*m | 200 ppmv*m | 2% | N ₂ |

Reference table: Standard applications. The specified pressures are absolute.

DL = detection limit

- The specification applies at 20 °C and 1013 hPa in a nitrogen atmosphere. In rare cases, a deviating process gas matrix or process conditions can have a negative effect on performance. Contact Siemens to determine the exact performance under your process conditions.
- With 0,3 m effective optical path length
Average diameter of the dust particles: 15 µm
Specific weight of the dust particles: 650 kg/m³
The influence of dust load is extremely complex and depends on the path length and particle size. The optical attenuation increases exponentially at longer path lengths. Smaller particles also have a very large influence on the optical attenuation. With high dust load, long path length and small particle size, the technical support at Siemens should be consulted.
- Based on measuring range. With stable or externally measured and software-compensated process gas temperature and pressure conditions.

Special applications

In addition to the standard applications, special applications are available upon request. If the process conditions deviate from the specifications of the standard applications, special applications are also possible on request.

- Complete the application questionnaire which can be found on the Internet at <http://www.siemens.com/insituquestionnaire>:

SIEMENS Fragebogen für in-situ Prozessanalyse

Kunde

Name: _____
 Anlage / Prozess: _____
 Kontaktperson: _____
 Adresse: _____
 Beverage Sprache: _____
 Tel: _____
 Fax: _____
 Email: _____

Siemens

Name / Ansprechpartner: _____
 Datum: _____
 Anfrage Nr.: _____
 Name: _____
 Adresse: _____
 Tel: _____
 Fax: _____
 Email: _____

Ergebnis Message (wenn machbar Angebotsdatum auf Seite 01)

Nur weiterleiten durch FA 13 Mitarbeiter!

Projekt Nr.: _____
 Kontaktperson FA 13: _____
 Machbarkeit der Messung: _____
 Angebot gültig bis: _____

WICHTIG: Anmerkungen

Die Sauerstoffmessung L1010 sollte an einem staubfreien und möglichst verschüttungsfreien Ort aufgestellt werden. Die Entfernung zwischen Zentralsensort und dem Messpunkt, d.h. dem Sauerstoff, sollte 100 Meter nicht überschreiten. Die relative Luftfeuchtigkeit darf 80% nicht übersteigen und die Umgebungstemperatur muss zwischen 5 - 45 °C betragen. Die Umgebungstemperatur am Installationsort der Sauerstoffmessung muss zwischen 10 - 15 °C betragen. Sauerstoff sollte in und abströmen sein. Instrumentenluft oder N2 sollten bereitgestellt werden mittels flexibler Verbindung mit einem Außenluftmesser. Darauf mittels G1/2" Verbindung. Zweite Installation und Service muss ein Premium von O2-Cellen um den senden und empfangenseitigen Sensor bestehen.

Siemens AG: Anmerkungen

Die relative Luftfeuchte muss kleiner 100% sein und die Umgebungstemperatur am Installationsort der Sauerstoffmessung muss zwischen 10 - 15 °C betragen. Das Sauerstoff N2 sollte bereitgestellt werden mittels flexibler Verbindung mit einem Außenluftmesser. Das Sauerstoff N2 sollte in und abströmen sein und einen Taupunkt < 10°C aufweisen. Um die bestmögliche Leistung zu erreichen sollte die N2-Reinheit >99,7% betragen und einen CO-Gehalt < 0,01% aufweisen. Kombination auf dem O2-Sensort ist zu vermeiden. Zweite Installation und Service muss ein Premium von O2-Cellen um den senden und empfangenseitigen Sensor bestehen.

Bedienung

- L1010: Die 4-Zinn-Analyse-Ausgabe sind aktiv (betriebsvorbereitet)

- Sitras SL: Die 4-Zinn-Analyse-Ausgabe sind passiv - ein zusätzlicher Speiseschleifer (7,5-30V) muss für jeden Analysengang bereitgestellt werden, z.B. Sitras 1

Siemens AG | FA 13 | FA 13 - 70370 Karlsruhe - Germany - Phone: +49 (0)611 989 7 322
 Email: support.sitras@siemens.com - www.siemens.com/insituquestionnaire

Technical specifications

Analytical performance

| | |
|---|--|
| Measuring range | Internally adjustable |
| Detection limit at standardized conditions: 25 °C gas temperature, 1 000 hPa, 1 m effective optical path length, 3 s integration time and constant ambient conditions. | O ₂ : 200 ppmv |
| Linearity (under standard conditions) | Better than 1% |
| Repeatability (under standard conditions) | O ₂ : 1% of the measuring range |

General information

| | |
|-----------------------------------|--|
| Design | Transmitter and detector units, connected by a sensor cable |
| Materials | <ul style="list-style-type: none"> • Sensor enclosure: Treated aluminum/stainless steel (1.4305/303) • Process interface: Acid-resistant stainless steel (1.4404/316L) • Window: hardened borosilicate glass • Compressible gaskets: FKM, FF, EPDM (holder for reference cell) • Flat gaskets: Graphite |
| Parts wetted by the process gases | <ul style="list-style-type: none"> • Purging tubes, flanges, window ring, process purging: acid-resistant stainless steel • Window: Borosilicate • Gasket in window: FFKM • Flat gasket between customer flange and process flange: Graphite |
| Installation | In-situ or bypass |
| Concentration units | ppm, vol.%, mg/Nm ³ |
| Display | Digital concentration display (4 digits with floating decimal point) |
| Laser protection class | Class 1, safe to the eye |
| Explosion protection | Optionally, according to <ul style="list-style-type: none"> • ATEX II 2G Ex de op is IIC T6 ATEX II 2D Ex tD A21 IP65 T85 °C • FM Class I, II, III Div 1 Groups A, B, C, D, E, F, G T6 • FM Class I, Zn 1, AEx d IIC T6 • FM Class II, Zn 21, AEx td T85 °C • XP Class I, II, III Div 1 Groups C, D T6 Ta = 55 °C; • DIP Class II, III Div 1 Groups E, F, G T6 Ta = 55 °C; Class I, Zn 1, Ex d IIC T6 Ta = 55 °C; Zn 21, Ex tD T85 °C Ta = 55 °C |

Design, enclosure

| | |
|--------------------------------------|---|
| Degree of protection | IP65 according to EN 60529 |
| Purging tube | <ul style="list-style-type: none"> • Length: 340 mm • Outer diameter: 48 mm • Inside diameter: 44 mm |
| Purging tube | Length, outer diameter, inner diameter: 340, 48, 44 mm |
| Weights | |
| • Detector unit | 6.0 kg |
| • Transmitter unit | 5.2 kg |
| • Process interface | |
| - for DN50/PN25 | 5.3 kg |
| - for ANSI4"/150 lbs | Approx. 12 kg |
| Connection dimension customer flange | DN 50/PN 25, DN 50/PN 40 or ANSI 4"/150 lbs |

Electrical characteristics

| | |
|----------------------------|------------------------------------|
| Auxiliary power | 24 V DC nominal (18 ... 30.2 V DC) |
| Power consumption, maximum | 10 VA |
| EMC | In accordance with EN 61326-1 |
| Electrical safety | In accordance with EN 61010-1 |
| Fuse specifications | T1.6L250V |

Dynamic performance

| | |
|---|-------------------------------------|
| Warm-up time at 20 °C ambient temperature | Approx. 15 min |
| Response time (T90) | Approx. 2 s, depends on application |
| Integration time | 0 ... 100 s, selectable |

Influencing variables

| | |
|------------------------------------|---|
| Variations in ambient temperature | < 0.5%/10 K of the measuring range |
| Process gas temperature | With compensation: < 1%/100 K of the measuring range |
| Variations in atmospheric pressure | Negligible |
| Process gas pressure | O ₂ : With compensation: < 1%/4 000 hPa of the measuring range |
| Variations in supply voltage | Negligible |

Electrical inputs and outputs

| | |
|--------------------------------|---|
| Number of measurement channels | 1 |
| Analog outputs | 2 outputs, 4 ... 20 mA, floating, ohmic resistance max. 660 Ω. External isolating power supplies may have to be provided by the customer. |
| Analog inputs | 2 inputs, designed for 4 ... 20 mA, 120 Ω |
| Digital outputs | 2 outputs, with switchover contacts, configurable, 24 V/0.5 A, floating, single pole double throw (SPDT) |
| Digital input | 1 input, designed for 24 V, floating, configurable |
| Service port | Ethernet 10BaseT (RJ-45) |
| RS 485 PROFIBUS DPV0 version | Two-wire interface, up to 3 Mbps, -7 ... 12 V |
| RS 485 Modbus version | Two-wire interface, up to 115 200 bit/s, -7 ... 12 V |

Connection cable to customer interface

| | |
|---|--|
| | Not included in standard delivery, permanently installed for ATEX or optional for standard |
| Analog connection cable (only supplied cables may be used for ATEX configuration!) | 10 x 2, with shielding in twisted-pair configuration (depending on type and number of I/Os used) |
| PROFIBUS DP connection cable (with ATEX configuration: only supplied cables may be used!) | 1 x 2 + 4 (PROFIBUS DP hybrid cable) |
| Modbus connection cable (with ATEX configuration: only supplied cables may be used!) | 1 x 2 + 3, with shielding in twisted-pair configuration |
| Cable length for ATEX configuration | 3 m |
| Conductor cross-section | Min. 0.34 mm ² |
| Cable diameter | 8 ... 12 mm or 13 ... 18 mm |
| Minimum bending radius ATEX-PROFIBUS | 110 mm |

In situ continuous process gas analysis

SITRANS SL

In situ O₂ gas analyzer

| | |
|---|--|
| Sensor cable | Not included in standard delivery, permanently installed for ATEX or optional for standard |
| Sensor cable type configuration | 4 x 2, with shielding, in twisted-pair configuration |
| Conductor cross-section | Min. 0.34 mm ² |
| Cable sheath | PUR (polyurethane) |
| Dimensions | <ul style="list-style-type: none"> • Diameter: 11 mm • Length: up to 25 m |
| Minimum bending radius | ATEX: 85 mm |
| Climatic conditions | |
| Ambient temperature range | <p>Note</p> <p>The display on the receiver side must not be exposed to direct solar radiation.</p> <ul style="list-style-type: none"> • -20 ... +55 °C during operation (additional solar radiation not permissible!) • -40 ... +70 °C during transport and storage |
| Temperature range on the sensor side of the process interface (connection plate) | -20 ... +70 °C |
| Atmospheric pressure | 800 ... 1100 hPa (for ATEX and FM version) |
| Humidity | < 100% rel. humidity |
| Measuring conditions | |
| Measurement path | 0.3 ... 8 m (other lengths: please contact Siemens) |
| Process gas pressure, temperature | <ul style="list-style-type: none"> • O₂: 900 ... 1 100 hPa, 0 ... 600 °C • O₂: 700 ... 5 000 hPa, 0 ... 200 °C |
| Dust load | The influence of a high dust load is complex, and depends on the optical path length and particle size distribution. |
| Purging | |
| Purging gas | Nitrogen (for O ₂ applications) |
| <ul style="list-style-type: none"> • Quality | O ₂ application: Purity better than 99.7% in order to achieve full performance. For oxygen measurements, an O ₂ content < 0.01 vol.% in the purging gas is recommended. |
| <ul style="list-style-type: none"> • Dew point | < -10 °C, condensation on the optics must be avoided |
| Sensor purging | |
| <ul style="list-style-type: none"> • Max. overpressure in the sensor • Purging gas temperature on sensor side | 500 hPa 0 ... +55 °C |
| <ul style="list-style-type: none"> • Flow | O ₂ application: When commissioning a sensor enclosure previously filled with air: 3 ... 5 l/min (for at least 15 min), subsequently: at least 0.25 l/min |
| Purging on the process side (optional) | |
| <ul style="list-style-type: none"> • Pressure at purging gas inlet • Flow | 2 000 ... 8 000 hPa Dependent on process gas pressure, process gas velocity, dust load, moisture, etc. up to max. 50 l/min |

In situ continuous process gas analysis SITRANS SL

In situ O₂ gas analyzer

Accessories

SITRANS SL sensor alignment kit

The SITRANS SL sensor alignment kit includes a battery-operated lamp, a centering aid with cross-hairs and two hook spanners for loosening the sensors from the flange connection plates.

Please note:

The SITRANS SL sensor alignment kit is not explosion-protected! Therefore it must never be used in a hazardous area without approval by the plant operator!

Calibration test kit

The SITRANS SL has already been factory-calibrated. If it is desirable or necessary to check the calibration, this can be performed using an external calibration test kit following removal of the transmitter and detector units. This procedure has no influence on the optical adjustment of the unit since the flange connection plates remain mounted on the customer flange. The calibration test kit for O₂ consists of a stainless steel calibration tube and a thermometer. To carry out the calibration, it is mounted between the transmitter and receiver. The calibration tube for O₂ can then be filled with air or a calibration gas.

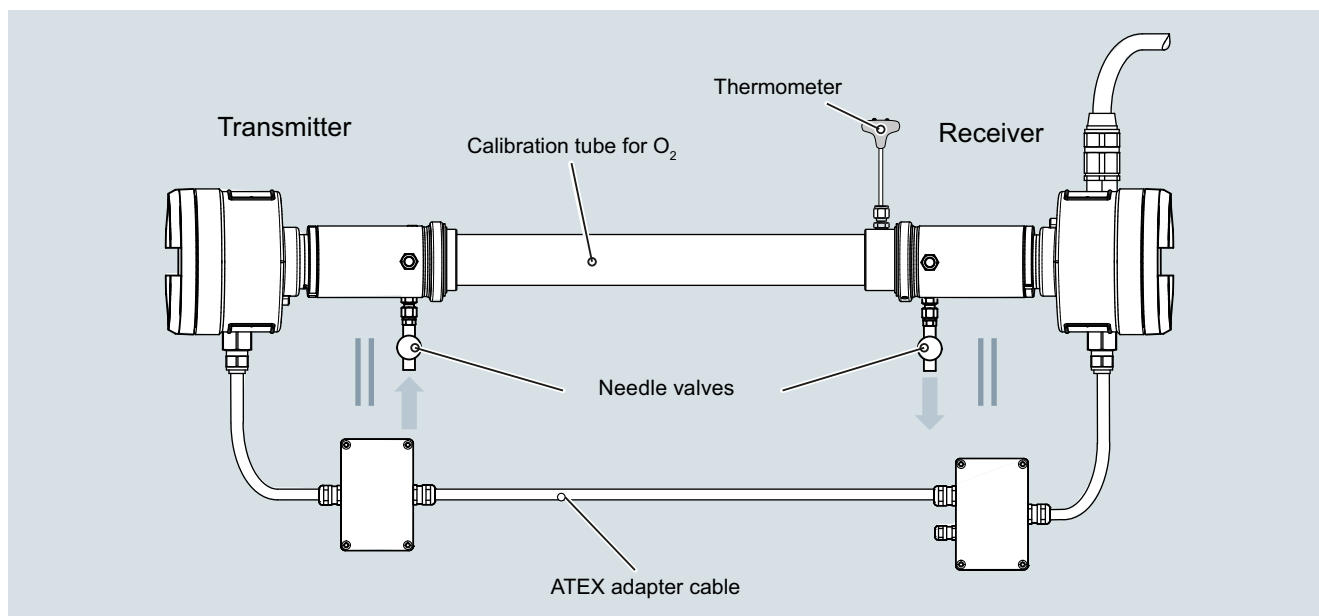

Calibration validation setup of SITRANS SL O₂

Additional accessories

You can find more accessories and spare parts in our PIA Life Cycle Portal product selector:
<http://www.pia-portal.automation.siemens.com>

In situ continuous process gas analysis

SITRANS SL

In situ O₂ gas analyzer

Dimensional drawings

Note

The SITRANS SL sensors must be accessible from the side. A space of at least 60 cm must be provided next to the SITRANS SL transmitter and detector units in order to facilitate maintenance and servicing.

To fulfill the safety requirements, a clearance of at least 10 cm must be provided around the SITRANS SL to maintain cooling.

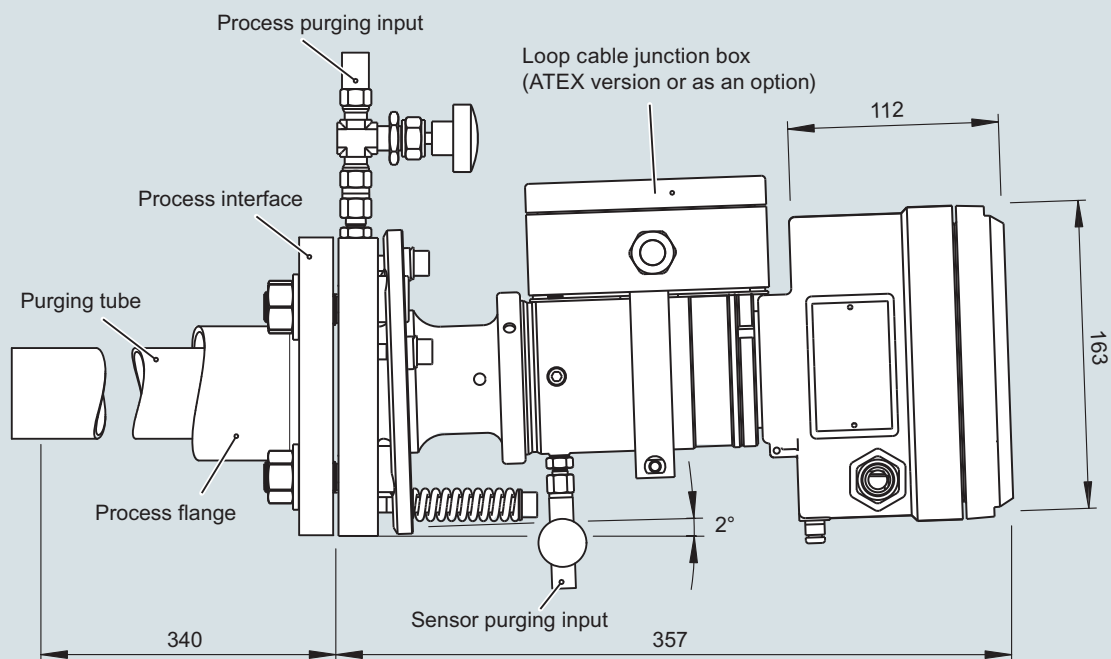

SITRANS SL, transmitter/detector unit (same housing for DN50/PN25 process interface version), dimensions in mm

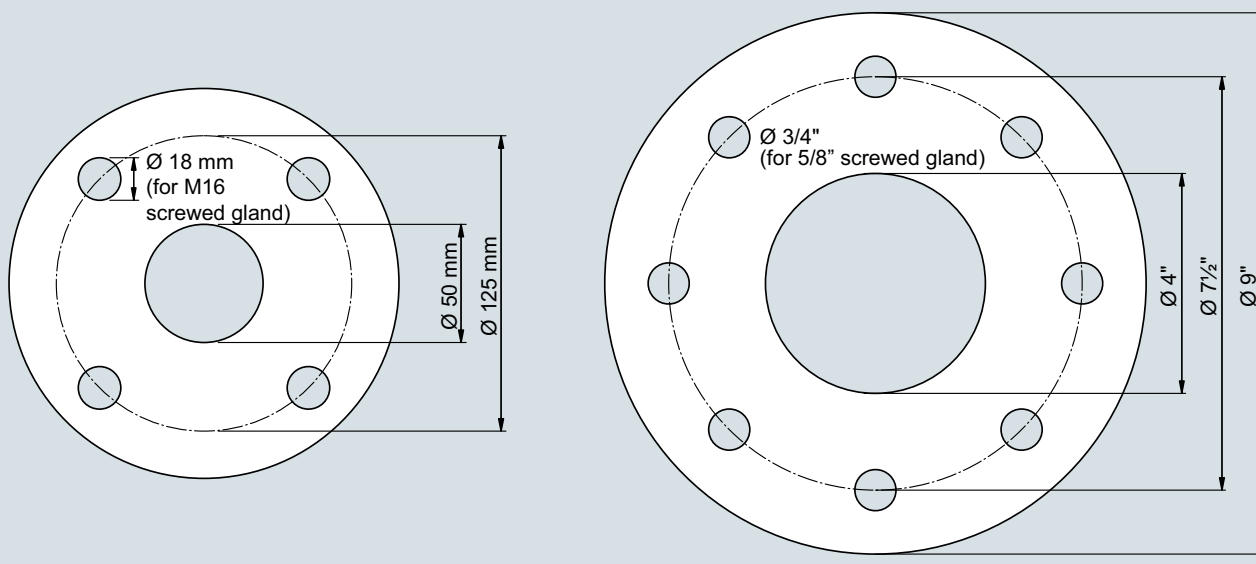

Connection dimensions of process flanges provided by customer DN50/PN25 and ANSI 4"/150 lbs

Circuit diagrams

Electrical connections

Non-hazardous area version connection cable - customer interface

| Terminal block in the receiver enclosure | | Function/voltage | Ethernet cable |
|--|--|---|-----------------------------|
| 1 | + | Power supply 19 ... 30.2 V, 10 VA ¹⁾ | |
| 2 | - | | |
| 3 | Normally closed under power ⁴⁾ | | |
| 4 | | Digital output 0 (relay) 30 V, 0.5 A ³⁾ | |
| 5 | Normally closed under power ⁴⁾ | | |
| 6 | | Digital output 1 (relay) 30 V, 0.5 A ³⁾ | |
| 7 | + | Digital input 0 0 ... 30 V ²⁾ | |
| 8 | - | | |
| 9 | + | Analog output 0 (measurement) 30 V, 24 mA ³⁾ | |
| 10 | - | | |
| 11 | + | Analog output 1 (measurement) 30 V, 24 mA ³⁾ | |
| 12 | - | | |
| 13 | PROFIBUS A line (RxD/TxD_N - data inverted) | Modbus D1 (RxD/TxD_N - data inverted) | RS 485 (PROFIBUS/Modbus) |
| 14 | PROFIBUS B line (RxD/TxD_P - data not inverted) | Modbus D0 (RxD/TxD_P - data not inverted) | -7 ... +12 V DC |
| 15 | PROFIBUS/Modbus shield | | |
| 16 | T _x + | Ethernet ⁵⁾ | White/orange |
| 17 | T _x - | | Orange |
| 18 | R _x + | | White/green |
| 19 | R _x - | | Green |
| 20 | + | Analog input 0 (temperature) 0 ... 30 mA ²⁾ , 120 Ω | |
| 21 | - | | |
| 22 | + | Analog input 1 (pressure) 0 ... 30 mA ²⁾ , 120 Ω | |
| 23 | - | | |
| 24 | | Grounding | |
| 25 | | Grounding | |
| Ground | | Grounding | |
| Ground | | Grounding | Shielding |

1) This is the maximum power consumption of the SITRANS SL

2) These are the maximum input values

3) These are the maximum output values

4) Note:

"Normal operation" stands for normal operation of the analyzer. The system is connected to the voltage source and is running without problems; no error message generated or displayed.

"Normal under power" refers to the status of the relay under the above-named normal operation. The relay contact of the alarm signal is closed.

5) We recommend that the Ethernet connection is not made via the cable to the Ethernet terminals in the detector unit. Instead, the Ethernet connection should be made via the sensor cable connection set which is optionally available for the detector unit.

In situ continuous process gas analysis

SITRANS SL

In situ O₂ gas analyzer

Examples of digital output and analog output

Caution

Please note that an external isolating power supply may be required!

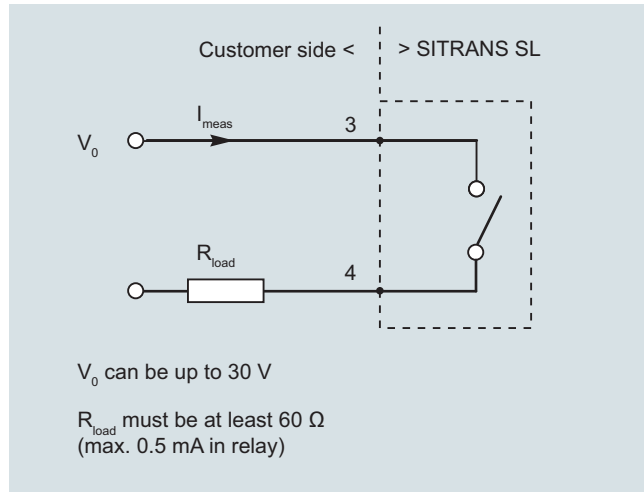

Example of digital output 0

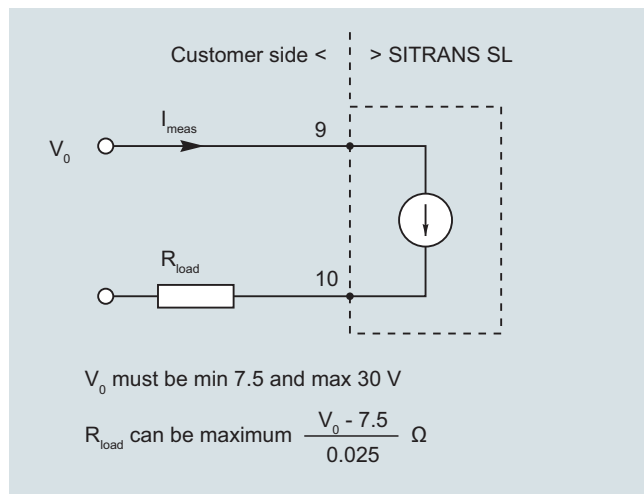

Example of an analog output 0

Sensor cable terminal box on the receiver side (ATEX version)

| Terminal strip in terminal box | Function | Color code | |
|--------------------------------|----------|---|-----------|
| 1 | + | 24 V DC voltage supply for transmitter unit | Red |
| 2 | - | | Blue |
| 3 | Com + | Communication with transmitter | Pink |
| 4 | Com - | | Gray |
| 5 | Sync + | Synchronization with transmitter | White |
| 6 | Sync - | | Brown |
| 7 | NC | Not used | - |
| 8 | Tx+ | Ethernet | Gray/pink |
| 9 | Tx- | | Red/blue |
| 10 | Rx+ | | Black |
| 11 | Rx- | | Violet |
| PE terminal | - | Grounding | Green |
| PE terminal | | Grounding | Yellow |
| Gland | | Grounding | Shielding |

In situ continuous process gas analysis SITRANS SL

In situ O2 gas analyzer

| Selection and ordering data | Article No. |
|---|---|
| SITRANS SL in-situ gas analyzer | 7MB6221- - - - - Cannot be combined |
| Click on the Article No. for the online configuration in the PIA Life Cycle Portal. | |
| Explosion protection¹⁾ Without Ex II 2 G Ex de op is IIC T6 Ex II 2 D Ex tD A21 IP65 T85°C FM USA: XP Class I, II, III Div 1 Groups A, B, C, D T6 Ta = 55°C DIP Class II,III DIV 1 Group EFG Ta = 55°C Class I, Zn 1, AEx d IIC T6 Ta = 55°C Zn 21, AEx tD T85°C Ta = 55°C FM Canada: XP Class I,II, III Div 1 Groups C, D T6 Ta = 55°C DIP Class II,III DIV 1 Group EFG Class I, Zn 1, Ex d IIC T6 Ta =55°C Class II, III Zn 21, Ex t IIC T85°C Ta = 55°C | 0 1 2 0 2 2 A B C 0 1 2 0 1 0 1 2 3 B C E X A B C D E F X 0 1 2 3 4 |
| Measured component O ₂ | A A |
| Application examples²⁾ Control of combustion processes Process control, safety monitoring in appropriate plant concepts | B C B A |
| Communication interface 2x analog I/O, 1x DI, 2x DO PROFIBUS DP Modbus | 0 1 2 |
| Purging tubes, material Length No purging tubes Stainless steel 340 mm | 0 1 |
| Purging: Process side Purging: Sensor side No purging No purging No purging 3 ... 5 l/min 0 ... 50 l/min No purging 0 ... 50 l/min 3 ... 5 l/min | 0 1 2 3 0 1 2 3 0 1 2 |
| Process connection³⁾ Stainless steel flange (1.4404/316L), connection dimensions ANSI 4"/150 lbs, MAWP (PS) at 20 °C: 232 psi Stainless steel flange (1.4404/316L), connection dimensions DN50/PN25, MAWP (PS) at 20 °C: 2.5 MPa Stainless steel flange (1.4404/316L), connection dimensions DN50/PN40, MAWP (PS) at 20 °C: 4.0 MPa Without process connection | B C E X E A B C D E F |
| Sensor cable With brass bushing • 5 m • 10 m • 25 m With stainless steel gland • 5 m • 10 m • 25 m Without cable | A B C D E F X A B C D E F A B C D E F |
| Documentation language German English French Spanish Italian | 0 1 2 3 4 |



1) Complete and consistent implementation of the safety concept by the plant operator must be ensured during the commissioning and operation of the in-situ laser spectrometer SITRANS SL in hazardous atmospheres.
 2) The examples shown represent possible applications where appropriately configured SITRANS SL solutions can be used. The user is responsible for the prevailing conditions (plant concept (possibly redundant), application of appropriate components required in addition, compliance with possible directives, etc.).
 3) MAWP: Maximum Allowable Working Pressure.

In situ continuous process gas analysis

SITRANS SL

In situ O₂ gas analyzer

Selection and ordering data

Additional versions

Add "-Z" to Article No. and specify Order code

Acceptance test certificate 3.1 (leak test) in accordance with EN 10204

Acceptance test certificate 3.1 (material certificate) in accordance with EN 10204

SIL 1 conformity declaration in accordance with standards IEC 61508/IEC 61511 (for the measured component oxygen in combination with analog interfaces)

TAG label, customized inscription

¹⁾ Together with explosion protection as per FM, on request

Order code

C12 ¹⁾

C13 ¹⁾

C20 ¹⁾

Y30

2

Selection and ordering data

Additional units and spare parts

Additional units

SITRANS SL, calibration test kit O₂,

SITRANS SL, sensor alignment kit

SITRANS SL, connection box Ex-e for 25-pin connecting cable

SITRANS SL, connecting cable set analog (for non-Ex)

SITRANS SL, connecting cable set PROFIBUS DP (for non-Ex)

SITRANS SL, UV protective hose for outdoor use, ND = 48 mm per 30 m length

SITRANS SL, sensor cable set (non-Ex) with cable glands of nickel-plated brass, length: 5 m

SITRANS SL, sensor cable set (non-Ex) with cable glands of nickel-plated brass, length: 10 m

SITRANS SL, sensor cable set (non-Ex) with cable glands of nickel-plated brass, length: 25 m

Spare parts

SITRANS SL, process connection plate (1 unit) for customer flange size: DN 50/PN 10 ... 40 including seal

SITRANS SL, gasket for DN 50/PN 10 ... 40

SITRANS SL, process connection plate (1 unit) for customer flange size: ANSI 4"/150 lbs including seal

SITRANS SL, gasket for ANSI 4"/150 lbs

SITRANS SL, purging tube 340 mm incl. seal for DN 50/PN 10 ... 40

SITRANS SL, window cover for detector unit

SITRANS SL, cover for transmitter unit

SITRANS SL, connecting cable for analog and Modbus (ATEX), cable gland of nickel-plated brass, for devices delivered after October 2009 (Version 1.1)

SITRANS SL, connecting cable for analog and Modbus (ATEX), cable gland of stainless steel

SITRANS SL, connecting cable for PROFIBUS DP (ATEX), cable gland of nickel-plated brass

SITRANS SL, cable for transmitter (ATEX), cable gland of nickel-plated brass

SITRANS SL, cable for detector (ATEX), cable gland of nickel-plated brass

SITRANS SL, connecting cable for PROFIBUS DP (ATEX), cable gland of stainless steel

SITRANS SL, connecting cable for transmitter (ATEX), cable gland of stainless steel

SITRANS SL, connecting cable for detector (ATEX), cable gland of stainless steel

SITRANS SL, terminal box and connecting cable for transmitter (ATEX), cable gland of stainless steel

SITRANS SL, terminal box (ATEX), cable gland brass, nickel-plated

SITRANS SL, terminal box and connecting cable for transmitter (ATEX), cable gland of nickel-plated brass

SITRANS SL, sensor cable 5 m

SITRANS SL, sensor cable 10 m

SITRANS SL, sensor cable 25 m

SITRANS SL, terminal box and connecting cable for detector (ATEX), cable gland of stainless steel

SITRANS SL, terminal box and connecting cable for detector (ATEX), cable gland of nickel-plated brass

SITRANS SL, cable gland for non-ex cables

SITRANS SL, screw cap

SITRANS SL, printed-circuit board for detector with LUI (Version 1.1)

SITRANS SL, remote control IS, CSA, FM, ATEX certifications

SITRANS SL, assembly kit for needle valve

SITRANS SL, assembly kit restrictor for sensor purging

Article No.

Item no. (see graphic on page 2/21)

A5E01000694

A5E01000740

A5E01267567

A5E03328474

A5E03328473

A5E01714061

A5E02509347

3+4+5

A5E02528048

3+4+5

A5E02528052

3+4+5

A5E01009881

A5E02522036

A5E01009883

A5E02789535

A5E01009892

A5E01009897

A5E02568437

A5E02608597

6

A5E34834297

6

A5E02608594

6

A5E44678580

2

A5E44678567

4

A5E34834296

6

A5E34830928

2

A5E34831050

4

A5E34831075

1

A5E02091532

1

A5E02568463

1+2

A5E02571180

5

A5E02571184

5

A5E02571186

5

A5E34831078

3

A5E02568465

3+4

A5E02568457

A5E01010033

A5E31503119

A5E02091214

A5E02569944

A5E02183375

Additional accessories

You can find more accessories and spare parts in our PIA Life Cycle Portal product selector:

<http://www.pia-portal.automation.siemens.com>

In situ continuous process gas analysis SITRANS SL

In situ O₂ gas analyzer

2

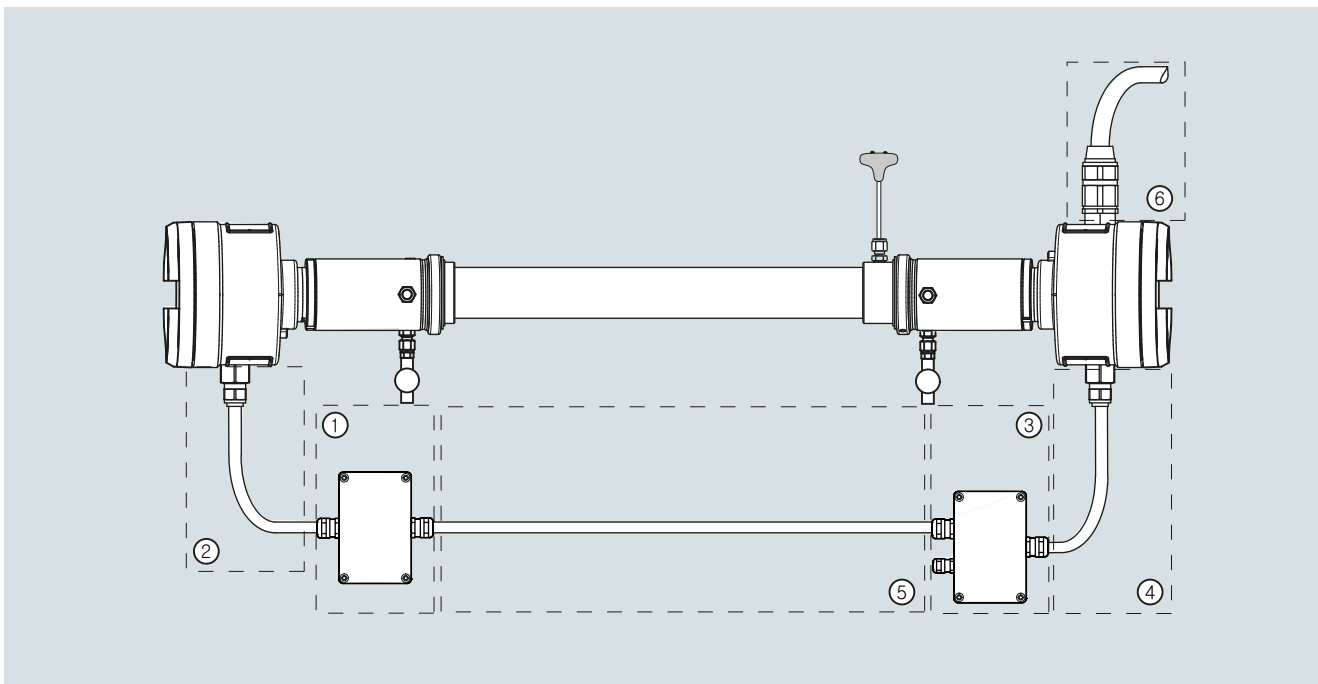

SITRANS SL spare parts, item numbers