

Dimensional drawings

SITRANS TS500, temperature sensors for vessels and pipelines, tubular version for minimal to medium stress, thermowell Type 2N similar to DIN 43722, screwed in, without extension, non-alignable connection head. For Ex-versions the maximum process temperature is 100 °C.

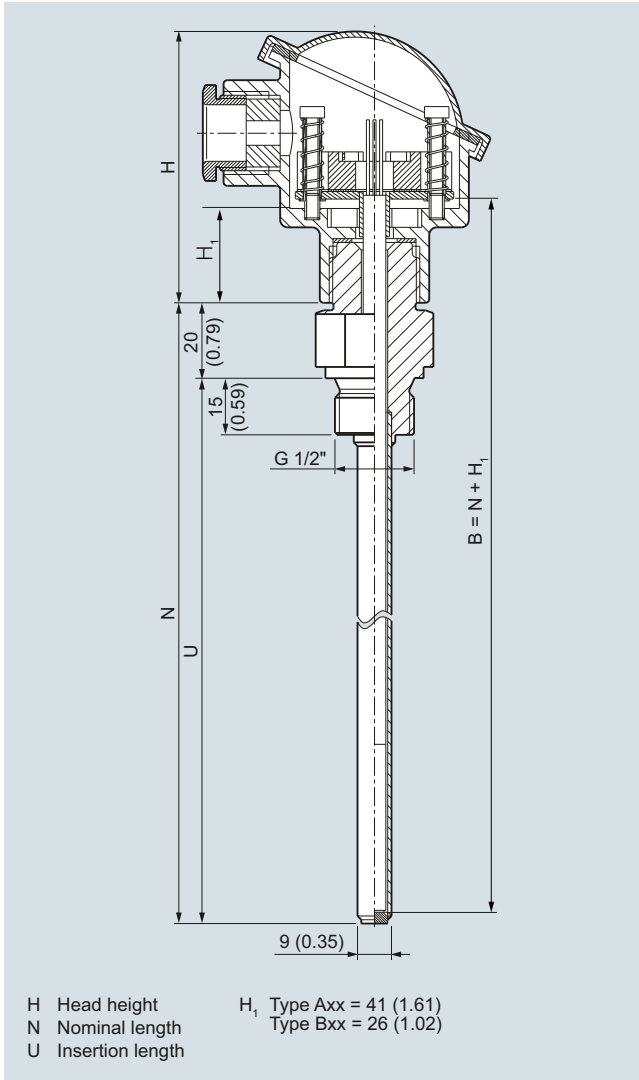

Connection type "G", dimensions in mm (inch)

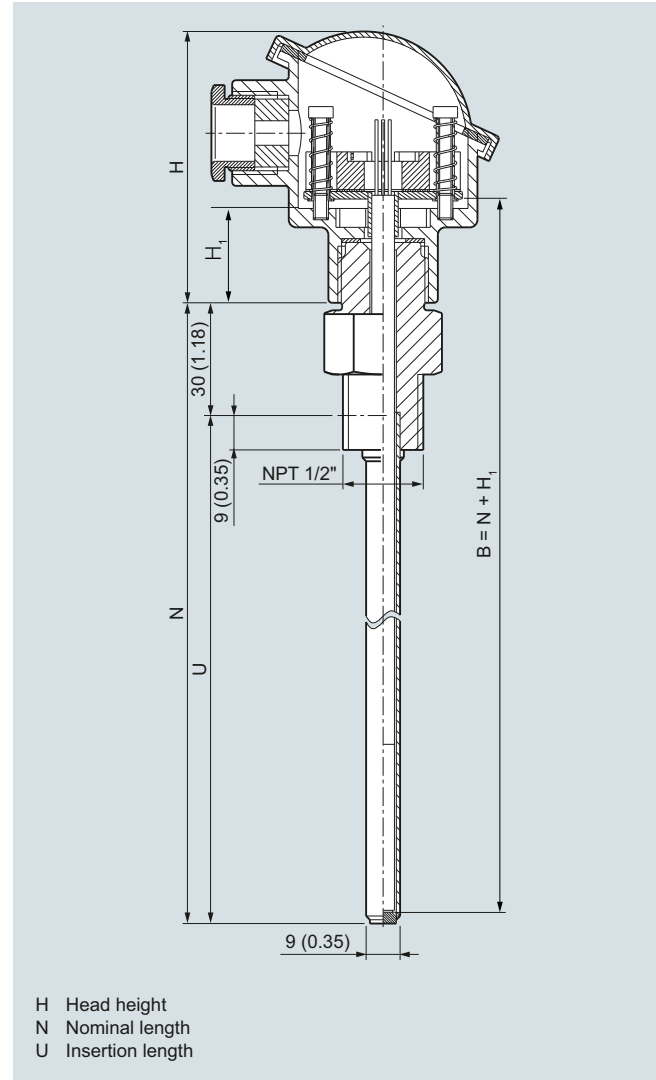

Connection type "NPT", dimensions in mm (inch)

Temperature Measurement SITRANS TS500

Type 2N, tubular version, with screw socket

2

Selection and Ordering data	Article No.
SITRANS TS500 Tubular thermowell, minimal to medium stress, Type 2N similar to DIN 43722, screwed in, without extension	7MC751-
Click on the Article No. for the online configuration in the PIA Life Cycle Portal.	
Material, in contact with media 316Ti (1.4571) 316L (1.4404 or 1.4435)	1 2
Process connection G ½" (½"BSPP) ½" NPT	1 C 1 J
Thermowell form 2N, 9 mm (0.35 inch)	A
Standard insertion length 100 mm (3.97 inch) 160 mm (6.30 inch) 230 mm (9.06 inch) 360 mm (14.17 inch) 510 mm (20.08 inch)	0 1 0 4 1 0 2 0 3 1
Customer-specific insertion length enter customer specific length with Y44, see page 2/64 Order codes	
80 ... 100 mm (3.15 ... 3.94 inch) Initial: 100 mm (3.94 inch)	0 1
101 ... 120 mm (3.98 ... 4.72 inch) Initial: 120 mm (4.72 inch)	0 2
121 ... 140 mm (4.76 ... 5.51 inch) Initial: 140 mm (5.51 inch)	0 3
141 ... 160 mm (5.55 ... 6.30 inch) Initial: 160 mm (6.30 inch)	0 4
161 ... 180 mm (6.34 ... 7.09 inch) Initial: 180 mm (7.09 inch)	0 5
181 ... 200 mm (7.13 ... 7.87 inch) Initial: 200 mm (7.87 inch)	0 6
201 ... 220 mm (7.91 ... 8.66 inch) Initial: 220 mm (8.66 inch)	0 7
221 ... 240 mm (8.70 ... 9.45 inch) Initial: 230 mm (9.06 inch)	1 0
241 ... 260 mm (9.49 ... 10.24 inch) Initial: 250 mm (9.84 inch)	1 2
261 ... 280 mm (10.28 ... 11.02 inch) Initial: 280 mm (11.02 inch)	1 3
281 ... 300 mm (11.06 ... 11.81 inch) Initial: 285 mm (11.22 inch)	1 4
301 ... 320 mm (11.85 ... 13.00 inch) Initial: 315 mm (12.40 inch)	1 5
321 ... 340 mm (12.64 ... 13.39 inch) Initial: 340 mm (13.39 inch)	1 6
341 ... 360 mm (13.43 ... 14.17 inch) Initial: 360 mm (14.17 inch)	2 0
361 ... 380 mm (14.21 ... 14.96 inch) Initial: 380 mm (14.96 inch)	2 1
381 ... 400 mm (14.99 ... 15.75 inch) Initial: 400 mm (15.75 inch)	2 2
401 ... 420 mm (15.79 ... 16.54 inch) Initial: 420 mm (16.54 inch)	2 3
421 ... 440 mm (16.57 ... 17.32 inch) Initial: 440 mm (17.32 inch)	2 4
441 ... 460 mm (17.36 ... 18.11 inch) Initial: 460 mm (18.11 inch)	2 5
461 ... 480 mm (18.15 ... 18.90 inch) Initial: 465 mm (18.30 inch)	2 6
481 ... 500 mm (18.94 ... 19.69 inch) Initial: 500 mm (19.69 inch)	2 7

Selection and Ordering data	Article No.
SITRANS TS500 Tubular thermowell, minimal to medium stress, Type 2N similar to DIN 43722, screwed in, without extension	7MC751-
501 ... 550 mm (19.72 ... 21.65 inch) Initial: 510 mm (20.08 inch)	3 1
551 ... 600 mm (21.69 ... 23.62 inch) Initial: 600 mm (23.62 inch)	3 2
601 ... 650 mm (23.66 ... 25.59 inch) Initial: 650 mm (25.59 inch)	3 3
651 ... 700 mm (25.63 ... 27.56 inch) Initial: 700 mm (27.56 inch)	3 4
701 ... 750 mm (27.60 ... 29.53 inch) Initial: 750 mm (29.53 inch)	3 5
751 ... 800 mm (29.57 ... 31.50 inch) Initial: 800 mm (31.50 inch)	3 6
801 ... 850 mm (31.54 ... 33.46 inch) Initial: 850 mm (33.46 inch)	3 7
851 ... 900 mm (33.50 ... 35.43 inch) Initial: 900 mm (35.43 inch)	4 1
901 ... 950 mm (35.47 ... 37.40 inch) Initial: 950 mm (37.40 inch)	4 2
951 ... 1 000 mm (37.44 ... 39.37 inch) Initial: 1 000 mm (39.37 inch)	4 3
1 001 ... 1 100 mm (39.41 ... 43.31 inch) Initial: 1 100 mm (43.31 inch)	4 4
1 101 ... 1 200 mm (43.35 ... 47.24 inch) Initial: 1 200 mm (47.24 inch)	4 5
1 201 ... 1 300 mm (47.28 ... 51.18 inch) Initial: 1 300 mm (51.18 inch)	4 6
1 301 ... 1 400 mm (51.22 ... 55.12 inch) Initial: 1400 mm (55.12 inch)	4 7
1 401 ... 1 500 mm (55.16 ... 59.05 inch) Initial: 1 500 mm (59.05 inch)	5 1
Extension X without neck tube, (not adjustable)	0

Additional configurations on page after next page!

You find ordering examples on page 2/41!

Temperature Measurement

SITRANS TS500

Type 2N, tubular version, with screw socket

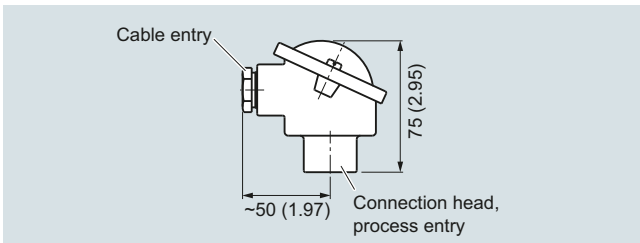

Connection head, aluminum, Type BA0, dimensions in mm (inch)

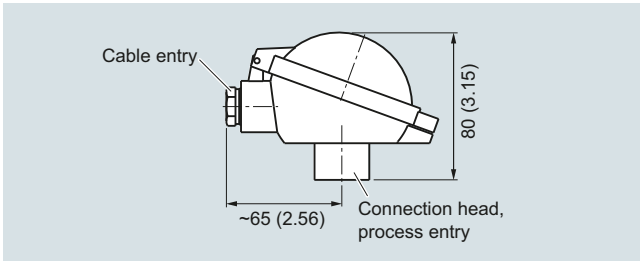

Connection head, aluminum, Type BB0, dimensions in mm (inch)

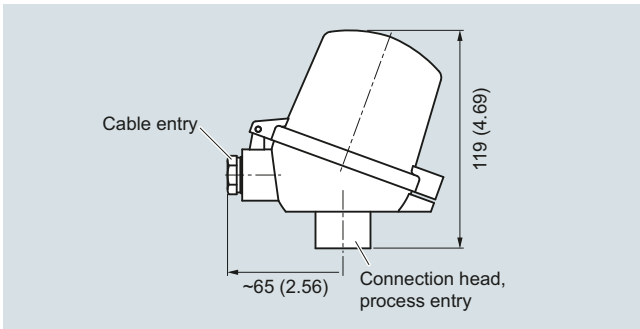

Connection head, aluminum, Type BC0, plastic, type BP0, dimensions in mm (inch)

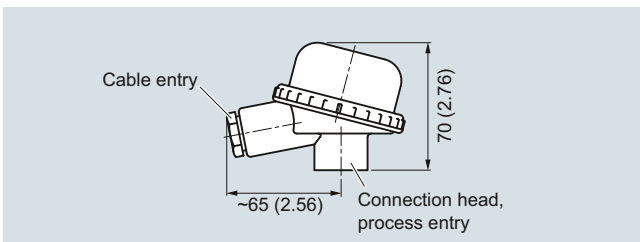

Connection head, plastic, Type BM0, dimensions in mm (inch)

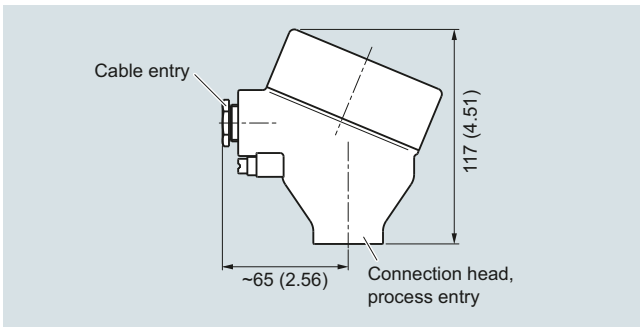

Connection head, aluminum, Type AG0, stainless steel, Type AU0, dimensions in mm (inch)

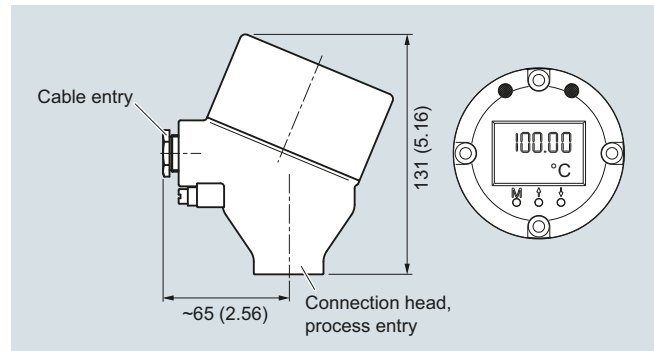

Connection head with 4-20 mA display, aluminum, Type AH0, stainless steel, Type AV0, dimensions in mm (inch)

Temperature Measurement

SITRANS TS500

Type 2N, tubular version, with screw socket

2

Selection and Ordering data	Article No.	Selection and Ordering data	Order code
SITRANS TS500 Tubular thermowell, minimal to medium stress, Type 2N similar to DIN 43722, screwed in, without extension, for maximum process temperatures of 100 °C	7MC751-	Options Add "-Z" to Article No. and add options, separate extensions with "+".	
Head Aluminum head, BA0, flange cover, Standard Aluminum head, BB0, low hinged cover, screw connection Aluminum head, BC0, high hinged cover, screw connection Aluminum head, AG0, screw cover, suitable for Ex d ¹⁾ Aluminum head, AH0, screw cover, suitable for Ex d, display ¹⁾ Plastic head, BM0, screw cover Plastic head, BP0, high hinged cover, screw connection Stainless steel head, AU0, screw cover, suitable for Ex d ¹⁾ Stainless steel head, AV0, screw cover, suitable for Ex d, display ¹⁾	A B C G H M P U V	Built-in head transmitter Measuring range to be set must be specified with plain text data "Y01". SITRANS TH100, 4 ... 20 mA, Pt100 SITRANS TH100 Ex i (ATEX), 4 ... 20 mA, Pt100 SITRANS TH200, 4 ... 20 mA, Universal SITRANS TH200 Ex i (ATEX), 4 ... 20 mA, Universal SITRANS TH300, HART, Universal SITRANS TH300 Ex i (ATEX), HART, Universal SITRANS TH400 PA, Universal SITRANS TH400 PA Ex i, Universal SITRANS TH400 FF, Universal SITRANS TH400 FF Ex i, Universal	T10 T11 T20 T21 T30 T31 T40 T41 T45 T46
Sensor²⁾ Please note: The accuracy class range can be lower than the measuring range. For more information, see page 2/18 Pt100, basis, -50 ... +400 °C (-58 ... +752 °F) Pt100, vibration-resistant, -50 ... +400 °C (-58 ... +752 °F) Pt100, expanded range, -196 ... +600 °C (-321 ... +1 112 °F) Thermocouple Type K, -40 ... +1 000 °C (-40 ... +1 832 °F) Thermocouple Type J, -40 ... +750 °C (-40 ... +1 382 °F) Thermocouple Type N, -40 ... +1 000 °C (-40 ... +1 832 °F)	A B C K J N	Explosion protection Without explosion protection requirements (Europe, Australia, New Zealand) Intrinsic safety "i"/"IS ¹⁾ " according to ATEX and IECEx (Europe, Australia, New Zealand) Flameproof enclosure "d"/"XP; dust protection through housing "t"/"DIP" ²⁾ according to ATEX and IECEx (Europe, Australia, New Zealand) Non-sparking "nA"/"NI" according to ATEX and IECEx (Europe, Australia, New Zealand) Without explosion protection requirements (USA, Canada) Basis FM Flameproof enclosure "d"/"XP; dust protection through housing "t"/"DIP" ²⁾ according to cFMus (USA, Canada); other connections (M,G,R) Non-sparking "nA"/"NI" according to cFMus (USA, Canada) Without explosion protection requirements (USA, Canada), Basis CSA Intrinsic safety "i"/"IS ¹⁾ " according to cCSAus (USA, Canada) Flameproof enclosure "d"/"XP; dust protection through housing "t"/"DIP" ²⁾ according to cCSAus (USA); other connections (M, G, R) Non-sparking "nA"/"NI" according to cCSAus (USA, Canada) Without explosion protection requirements (China) Intrinsic safety "i"/"IS ¹⁾ " according to NEPSI (China) Flameproof enclosure "d"; dust protection through housing "t" ²⁾ according to NEPSI (China) Non-sparking "nA"/"NI" according to NEPSI (China) Without explosion protection requirements (EAC) Intrinsic safety "i"/"IS ¹⁾ " according to EACEx (EAC) Flameproof enclosure "d"/"XP; dust protection through housing "t"/"DIP" ²⁾ according to EACEx (EAC) Non-sparking "nA"/"NI" according to EACEx (EAC)	E00 E01 E03 E04 E10 E14 E16 E17 E18 E21 E23 E54 E55 E56 E57 E80 E81 E82 E83
Sensor number/Accuracy Circuit Pt 100: 1 x 4-wire circuit or 2 x 3-wire circuit, see "Measuring technique: Connection types", page 2/20 Single, basic accuracy (Class 2/Class B) Single, increased accuracy (Class 1/Class A) Single, highest accuracy (Class AA) Double, basic accuracy (Class 2/Class B) Double, increased accuracy (Class 1/Class A) Double, highest accuracy (Class AA)	1 2 3 5 6 7	Marine approvals Det Norske Veritas Germanischer Lloyd (DNV GL) Bureau Veritas (BV) Lloyd's Register of Shipping (LR) American Bureau of Shipping (ABS)	D01 D02 D04 D05
Selection and Ordering data	Order code	Certificates and approvals EN 10204-3.1 Inspection certificate for materials coming into contact with media EN 10204-3.1 Inspection certificate for hydrostatic pressure test EN 10204-3.1 Inspection certificate for helium leak test EN 10204-3.1 Inspection certificate for surface tear test EN 10204-3.1 Inspection certificate: visual, measurement and functional inspection EN 10204-2.1: Declaration of compliance with the order ISO 9001 grease-free (cleaned for e.g. oxygen applications)	C12 C31 C32 C33 C34 C35 C51
Further designs Add "-Z" to Article No. and specify Order code.			
Insertion length customer-specific Select range, enter desired length in plain text (No entry = standard length)	Y44		

Selection and Ordering data	Order code
Designation, calibration	
Stainless steel TAG plate , enter lettering in plain text	Y15
Plant calibration per 1 point, enter temperature in plain text	Y33
Transmitter options	
Transmitter, enter complete setting in plain text (Y01: +/-NNNN ... +/-NNNN C,F), marking on the device when Order code "Y15" is selected	Y01
Enter measuring point (max. 8 characters) in plain text	Y17
Transmitter, enter measuring point description (max. 16 characters) in plain text	Y23
Transmitter, enter measuring point text (max. 32 characters) in plain text	Y24
Transmitter, enter bus address in plain text	Y25
Transmitter, fail-safe value 3.6 mA (instead of 22.8 mA)	U36
Transmitter with a SIL 2 conformity	C20
Transmitter with a SIL 2/3 conformity	C23
Transmitter test protocol (5 points)	C11
Further options	
Connection form, flying leads (for the direct transmitter assembly, delivery without screws and springs)	G01
M12 device plug (in combination with 1x Pt100 and/or transmitter, Non-Ex and intrinsically safe, max. IP65/67)	G12
Han 7D device plug (Non Ex and intrinsically safe, without mating connector max. IP65/67)	G13
Connection head with ½" NPT thread without cable gland, for AU0 and AH0 only IP66	G20
with outer earth screw for heads AG0, AH0, AU0 and AV0	A02
with inner earth screw for heads BC0, AG0, AH0, AU0 and AV0	A03
Option not found?	
Handling number special version	Y99

1) Please select Ex i version of the optional transmitter.

2) Only with connection heads code AG0, AH0, AU0, AV0, without cable gland (please select non-Ex version of the optional transmitter).

You find ordering examples on page 2/41.

Accessories, see page 2/238.