



## OPTIBAR DS SERIES Technical Datasheet

### Diaphragm seal systems

- Diaphragm seal flange design
- Diaphragm seal flange design with extension
- Diaphragm seal with threaded connection or open measuring flange

<b>1</b>	<b>General information</b>	<b>3</b>
<hr/>		
1.1	Application areas .....	3
1.2	Measuring principle.....	3
1.3	Design .....	4
1.4	Diaphragm .....	5
1.5	Fill fluid .....	6
1.6	Negative pressure and vacuum service .....	7
1.6.1	Silicone oil.....	8
1.6.2	Silicone-free synthetic oil.....	9
1.6.3	Vacuum and high-temperature oil .....	10
1.6.4	Halocarbon oil.....	11
1.6.5	Glycerin/water mixture .....	12
<b>2</b>	<b>Mounting</b>	<b>13</b>
<hr/>		
2.1	General terms and conditions.....	13
2.2	Device installation with capillary tubes .....	13
2.3	Attaching the capillary tube .....	14
2.4	Use in hazardous areas .....	14
<b>3</b>	<b>Maintenance</b>	<b>15</b>
<hr/>		
3.1	Maintenance advice .....	15
3.2	Returning the device to the manufacturer.....	15
3.2.1	General information.....	15
3.2.2	Form (for copying) to accompany a returned device.....	16
3.3	Disposal .....	16
<b>4</b>	<b>Diaphragm seal</b>	<b>17</b>
<hr/>		
4.1	Diaphragm seals for general applications.....	17
4.1.1	Flange diaphragm seals .....	17
4.1.2	Flange diaphragm seal with extension.....	20
4.2	Diaphragm seals for special applications.....	23
4.2.1	Threaded diaphragm seals and open measuring flange .....	23
<b>5</b>	<b>Order information</b>	<b>26</b>
<hr/>		
5.1	OPTIBAR DSP .....	26
5.1.1	OPTIBAR DSP 3000 .....	26
5.1.2	OPTIBAR DSP 2000 .....	29
5.2	OPTIBAR DSD .....	32
5.2.1	OPTIBAR DSD 3100 .....	32
5.2.2	OPTIBAR DSD 3110 .....	34
5.2.3	OPTIBAR DSD 3210 .....	37
5.2.4	OPTIBAR DSD 3220 .....	40
5.3	Accessories.....	43
5.3.1	Flushing ring .....	43

## 1.1 Application areas

Diaphragm seals are designed to separate pressure transmitters to prevent the product from getting into the measuring system. By selecting the right diaphragm seal you can complete measuring tasks that often would not be possible using the pressure transmitter alone.

### Examples of use:

- With aggressive, corrosive, highly viscous, solidifying or abrasive products.
- At high product temperatures or temperature fluctuations.
- Protect the pressure transmitter from vibration by connecting capillary tubes.
- Damping of pressure fluctuations and surges.
- Dead zone free arrangement of measuring points under particularly hygienic conditions.
- Use of special materials or surface coatings on wetted parts for special applications.

## 1.2 Measuring principle

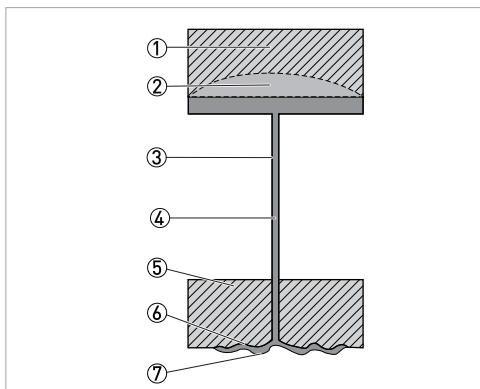

Figure 1-1: Overview measuring principle

- ① Pressure transmitter
- ② Measuring element
- ③ Capillary tube
- ④ Fill fluid
- ⑤ Diaphragm seal base body
- ⑥ Diaphragm base
- ⑦ Diaphragm

In a diaphragm seal system, the process pressure acts through a diaphragm without deflecting force ⑦ on a fill fluid ④, which moves the measuring element ② of the pressure transmitter ① via a tube (possibly capillary tube ③).

The zero point stability of a pressure transmitter with connected diaphragm seal is heavily influenced by the temperature-dependent fluctuations in volume of the fill fluid. These fluctuations in volume must be absorbed by a deflection of the diaphragm seal diaphragm.

### 1.3 Design

The design of the diaphragm seal depends on the special requirements of the respective process. We can distinguish between flange diaphragm seals, flange diaphragm seals with extension and threaded diaphragm seals.

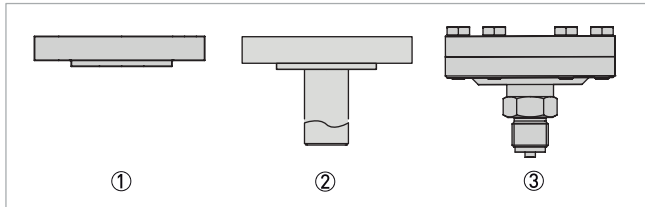

Figure 1-2: Overview design

- ① Flange diaphragm seals
- ② Flange diaphragm seals with extension
- ③ Threaded diaphragm seals

The connection between the pressure transmitter and the diaphragm seal can either be direct (using a cooling fin, no cooling fin or as a 90° angled design) or via a capillary tube when, for example, it is necessary to keep elevated temperatures or vibrations away from the pressure transmitter. Capillary tubes feature a throttle effect which is often desirable in the case of pulsating process pressures.

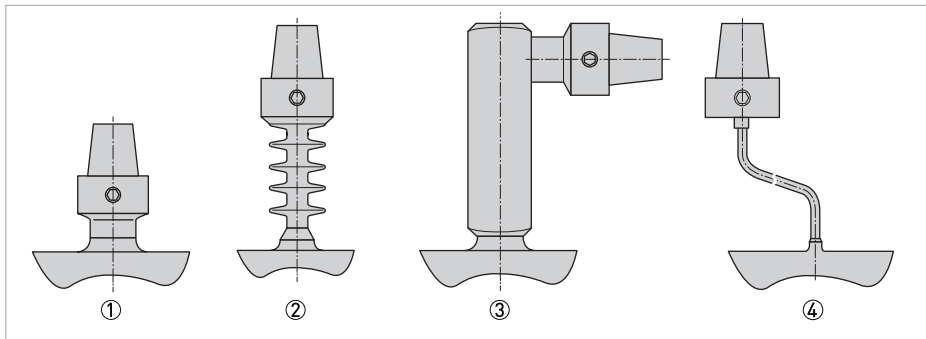

Figure 1-3: Overview connection

- ① Direct connection without cooling fins
- ② Direct connection with cooling fins
- ③ Direct connection with 90° right angle design
- ④ Connection with capillary tube

## 1.4 Diaphragm

The diaphragm determines the characteristic properties of the diaphragm seal that are important for the design and error analysis of the diaphragm seal system. The most important parameter is the stiffness in the error analysis. This mainly depends on the following:

- Material thickness
- Material
- Nominal diameter
- Diaphragm contour

### Material

Material	Temperature
316L (1.4404 / 1.4435)	max. 400°C
Hastelloy C-276 (2.4819)	max. 400°C
Tantalum	max. 400°C
Titan Grade 2 (3.7035/34)	max. 400°C
Monel 400 (2.4360)	max. 400°C
Duplex (1.4462)	max. 200°C

Diaphragm seal systems with stainless steel diaphragm or diaphragm made of special materials are largely resistant to chemical effects in the area in contact with the product. Coating with Gold, PFA or PTFE film provides a further level of protection.

Material with coating	Temperature
316L with PTFE-foil; 130...300 µm	max. 200°C (<0 bar rel.) max. 260°C (0...25 bar rel.) max. 150°C (25...40 bar rel.) max. 50°C (40...1000 bar rel.)
316L with PFA coating; 40...50 µm	max. 200°C (<0 bar rel.) max. 260°C (0...25 bar rel.) max. 150°C (25...40 bar rel.) max. 50°C (40...1000 bar rel.)
316L with Gold coating; 6 µm	max. 400°C

### Error calculation

Active diaphragm surface	Process temperature effect
Approx. Ø 85 mm	<0.1 mbar /10K (0.01% / 10K at 1000 mbar nominal range)
Approx. Ø 65 mm	<0.2 mbar /10K (0.02% / 10K at 1000 mbar nominal range)
Approx. Ø 50 mm	<0.4 mbar /10K (0.04% / 10K at 1000 mbar nominal range)

The following generally applies:

The larger the diaphragm the smaller the temperature error.

## 1.5 Fill fluid

Fill fluids transfer the process pressure from the diaphragm seal diaphragm to the sensor element and are thus an elementary component of the diaphragm seal system.

Depending on the application, there are several substances with different properties available as fill fluids. The following table contains the typical values of each fill fluid.

Label	Type	t <sub>min</sub> [°C]	t <sub>max</sub> [°C]	Density [g/cm <sup>3</sup> ]	Kin. viscosity @ 40°C [mm <sup>2</sup> /s]	Tk [%/10K]	Compressibility [%/100 bar]
Silicone oil	Viscous silicone oil	-50	300	0.96	40	1.0	1.02
Silicone-free synthetic oil	Polyalphaolefin oil	-50	230	0.82	31	0.76	0.6
Vacuum and high-temperature oil	Highly refined mineral oil	-10	400	0.87	95	0.73	1
Halocarbon oil	Halogenated carbon chains	-30	190	1.92	56	0.9	0.73
Glycerin/water mixture	Glycerin/water 70%/30%	-30	110	1.18	8	0.57	0.29

Important influencing factors when selecting a fill fluid include the process conditions as regards pressure and temperature. The temperature range is the result of the physical properties of the fill fluid. In addition, the process pressure is also significant as a combination of high temperature and a pressure in the vacuum range is particularly critical. Depending on the critical process point, special production steps may have to be carried out to ensure the suitability of the diaphragm seal system.

## 1.6 Negative pressure and vacuum service

Some fill fluids can be easily operated in the vacuum when the installation site for the diaphragm seal is suitable for vacuums up to a limit temperature of ( $t_1$ ). At higher temperatures, special handling is necessary during production. Here we distinguish between negative pressure service and the particularly high-quality vacuum service.

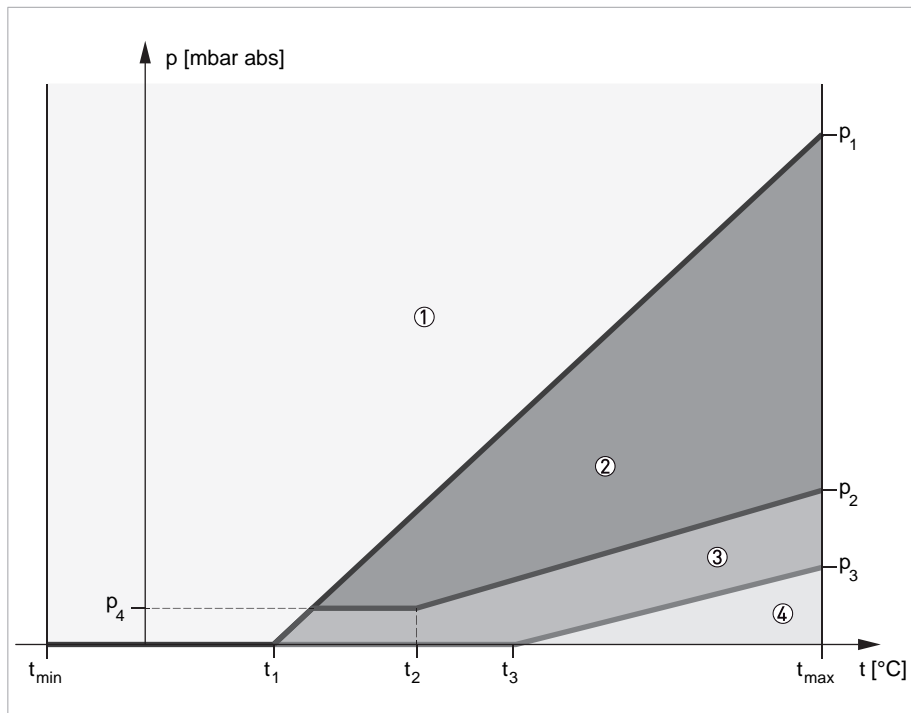

Figure 1-4: Overview negative pressure and vacuum service

- ① Standard service
- ② Negative pressure service
- ③ Vacuum service
- ④ Consultation required

$t_{\min}$	Minimum permissible temperatures for the fill fluid
$t_1$	Maximum temperature for vacuum vacuum service
$t_2$	Limit temperature between vacuum and negative pressure service at 30 mbar abs. ( $p_4$ )
$t_3$	Maximum temperature for vacuum vacuum service
$t_{\max}$	Maximum permissible temperature of fill fluid
$p_1$	Minimum pressure at $t_{\max}$ and standard service
$p_2$	Minimum pressure at $t_{\max}$ and negative pressure service
$p_3$	Minimum pressure at $t_{\max}$ and vacuum service
$p_4$	30 mbar abs

The different zones are separated by three straight lines. The range under 30 mbar abs ( $p_4$ ) is a special case. This range always requires the vacuum service starting at the abovementioned limit temperature ( $t_1$ ) and in the case of particularly critical process points, it is necessary to consult with the technical support team.

1.6.1 Silicone oil

Field of application

Viscous silicone oil, particularly suited to standard applications up to temperatures of 300°C.

Physical properties

Density	0.96 g/cm <sup>3</sup>
Viscosity (at 40°C)	40 mm <sup>2</sup> /s
t <sub>min</sub>	-50°C
t <sub>max</sub>	300°C

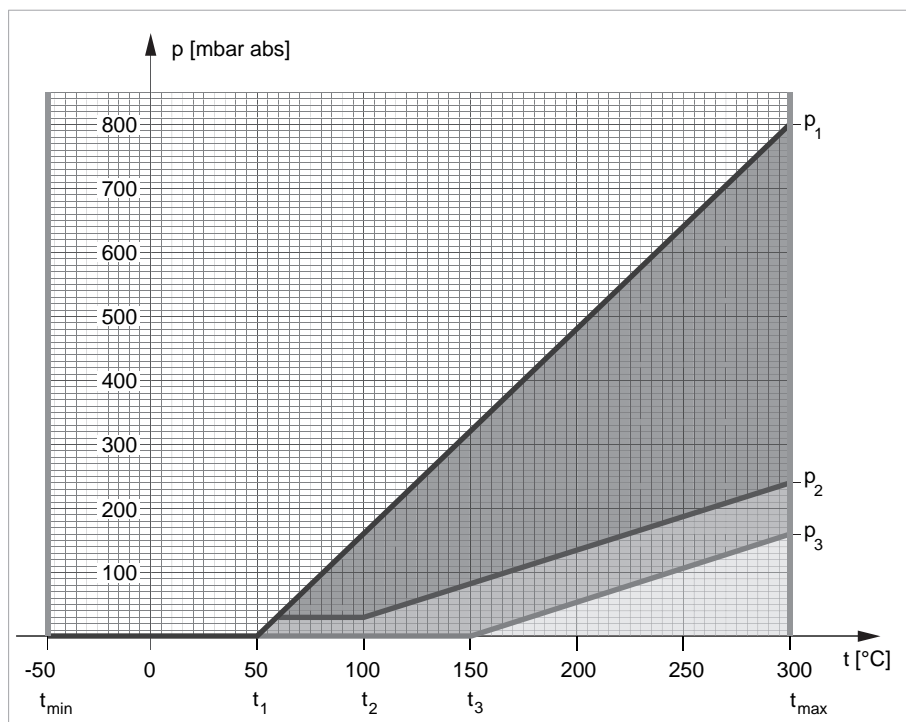

Data for the pressure/temperature graph

t <sub>1</sub>	50°C	Maximum temperature for vacuum + standard service
t <sub>2</sub>	100°C	Limit temperature between vacuum and negative pressure service at 30 mbar absolute
t <sub>3</sub>	150°C	Maximum temperature at vacuum + vacuum service
p <sub>1</sub>	800 mbar absolute	Minimum pressure at t <sub>max</sub> and standard service
p <sub>2</sub>	240 mbar absolute	Minimum pressure at t <sub>max</sub> and negative pressure service
p <sub>3</sub>	160 mbar absolute	Minimum pressure at t <sub>max</sub> and vacuum service



## 1.6.2 Silicone-free synthetic oil

### Field of application

Silicone-free, synthetic oil with universal properties, particularly well-suited for food and pharmaceutical applications

Meets FDA 21 CFR 178.3570 requirements for lubricants with occasional food contact and is registered as H1.

### Physical properties

Density	0.82 g/cm <sup>3</sup>
Viscosity (at 40°C)	31 mm <sup>2</sup> /s
t <sub>min</sub>	-50°C
t <sub>max</sub>	230°C

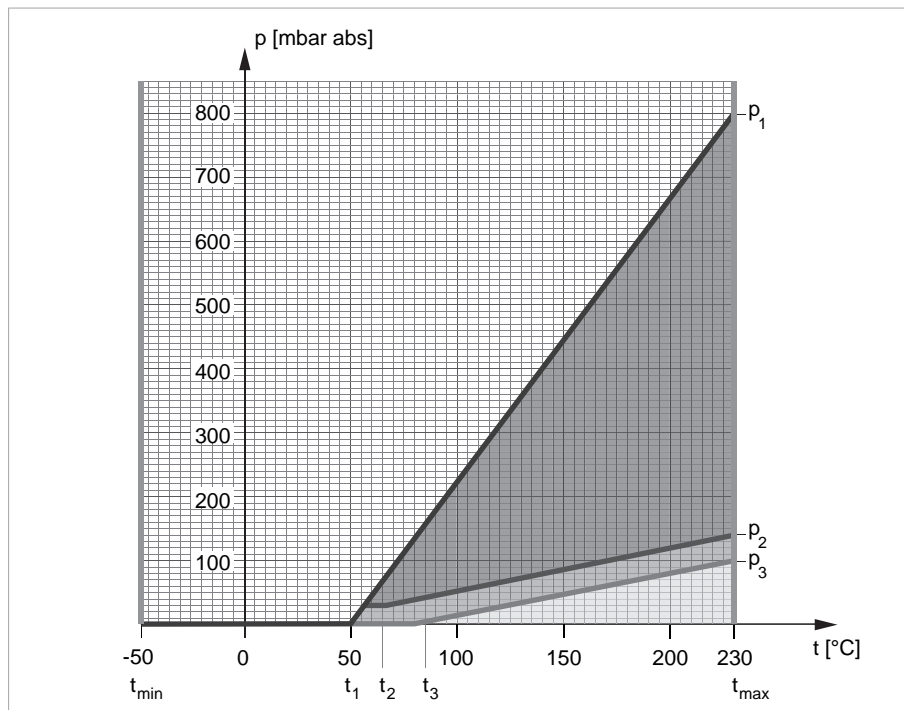

### Data for the pressure/temperature graph

t <sub>1</sub>	50°C	Maximum temperature for vacuum + standard service
t <sub>2</sub>	65°C	Limit temperature between vacuum and negative pressure service at 30 mbar absolute
t <sub>3</sub>	80°C	Maximum temperature for + vacuum service
p <sub>1</sub>	800 mbar absolute	Minimum pressure at t <sub>max</sub> and standard service
p <sub>2</sub>	140 mbar absolute	Minimum pressure at t <sub>max</sub> and negative pressure service
p <sub>3</sub>	100 mbar absolute	Minimum pressure at t <sub>max</sub> and vacuum service

1.6.3 Vacuum and high-temperature oil

Field of application

Silicone-free mineral oil especially well suited at high temperatures as well as vacuum applications under temperature.

Physical properties

Density	0.87 g/cm <sup>3</sup>
Viscosity (at 40°C)	95 mm <sup>2</sup> /s
t <sub>min</sub>	-10°C
t <sub>max</sub>	400°C

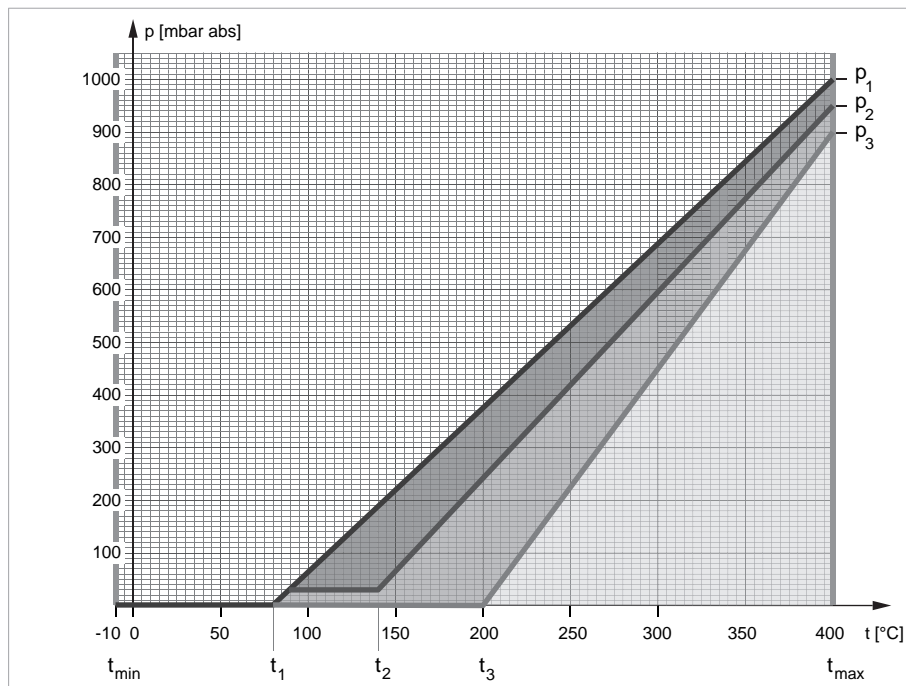

Data for the pressure/temperature graph

t <sub>1</sub>	80°C	Maximum temperature for vacuum + standard service
t <sub>2</sub>	140°C	Limit temperature between vacuum and negative pressure service at 30 mbar absolute
t <sub>3</sub>	200°C	Maximum temperature for + vacuum service
p <sub>1</sub>	1000 mbar absolute	Minimum pressure at t <sub>max</sub> and standard service
p <sub>2</sub>	950 mbar absolute	Minimum pressure at t <sub>max</sub> and negative pressure service
p <sub>3</sub>	900 mbar absolute	Minimum pressure at t <sub>max</sub> and vacuum service

### 1.6.4 Halocarbon oil

#### Field of application

Inert, silicone-free halocarbon oil, particularly suited for oxygen applications.  
BAM approval up to 60°C at 80 bar.

#### Physical properties

Density	1.92 g/cm <sup>3</sup>
Viscosity (at 40°C)	56 mm <sup>2</sup> /s
t <sub>min</sub>	-30°C
t <sub>max</sub>	60°C for oxygen applications 190°C for standard applications

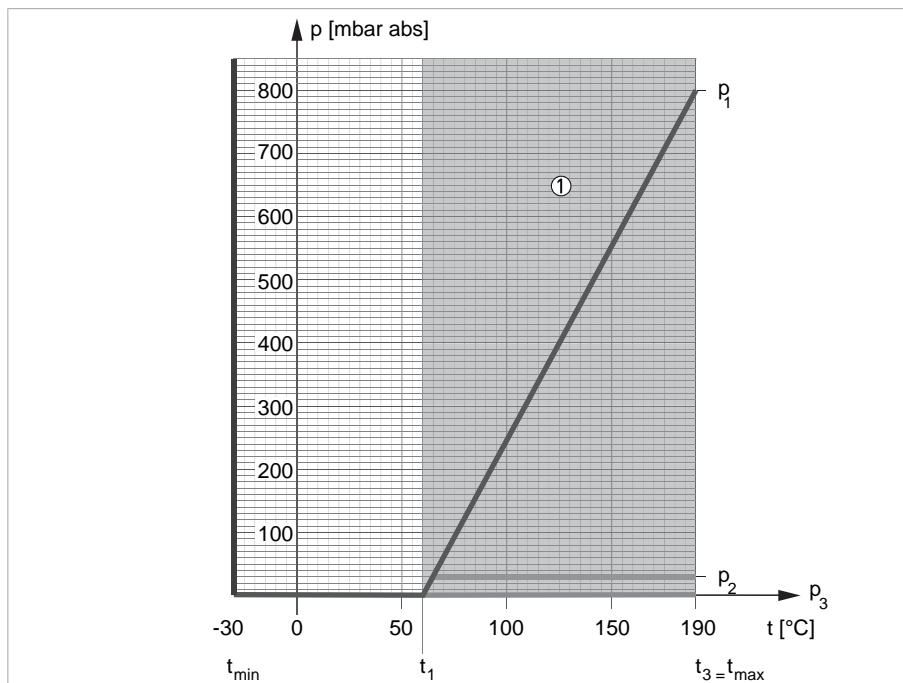

① Not for oxygen applications

#### Data for the pressure/temperature graph

t <sub>1</sub>	60°C	Maximum temperature for vacuum + standard service
t <sub>2</sub>	n/a	n/a
t <sub>3</sub>	190°C	Maximum temperature for + vacuum service
p <sub>1</sub>	800 mbar absolute	Minimum pressure at t <sub>max</sub> and standard service
p <sub>2</sub>	30 mbar absolute	Minimum pressure at t <sub>max</sub> and negative pressure service
p <sub>3</sub>	0 mbar absolute	Minimum pressure at t <sub>max</sub> and vacuum service

1.6.5 Glycerin/water mixture

Field of application

The glycerin/water mixture features good physical properties (very low compressibility, low temperature expansion and viscosity). The temperature range ends at 110°C.

Physical properties

Density	1.18 g/cm <sup>3</sup>
Viscosity (at 40°C)	8 mm <sup>2</sup> /s
t <sub>min</sub>	-30°C
t <sub>max</sub>	110°C

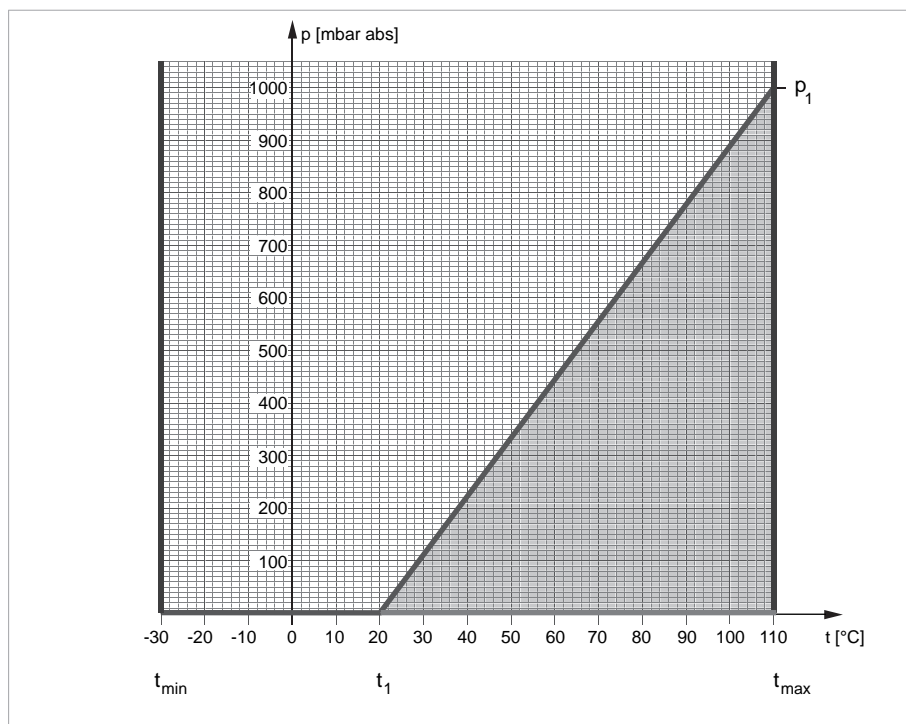

Data for the pressure/temperature graph

t <sub>1</sub>	20°C	Maximum temperature for vacuum + standard service
t <sub>2</sub>	n/a	n/a
t <sub>3</sub>	n/a	n/a
p <sub>1</sub>	1000 mbar absolute	Minimum pressure at t <sub>max</sub> and standard service
p <sub>2</sub>	n/a	n/a
p <sub>3</sub>	n/a	n/a

## 2.1 General terms and conditions

- The protective cover in front of the separating diaphragm may only be removed immediately prior to installation in order to avoid contamination or damage.  
Keep the protective cover so that the separating diaphragm is not damaged in transport in case the device needs to be sent back.
- Do not touch the separating diaphragm with fingers or other objects and do not place the diaphragm side of the diaphragm seal on hard surfaces. Even small dents or scratches in the diaphragm material can negatively influence the measuring properties of the diaphragm seal system.
- The pressure transmitter and diaphragm seal form a closed diaphragm seal system and may thus not be separated or opened.
- The process seal may not press on the diaphragm surface. Any pressure on the diaphragm is registered as process pressure. This means that an incorrectly aligned seal or one that is too small can lead to incorrect measuring results. In the process, ensure that the seal fits properly on the raised face.

## 2.2 Device installation with capillary tubes

When it comes to installation, we recommend that the pressure transmitter be installed at the same height if possible, ideally underneath the diaphragm seal in order to avoid tearing off the fluid column in the event of greater height differences.

In the event of negative pressure measurements, ensure that the pressure transmitter is installed below the diaphragm seal.

Under atmospheric conditions, the height difference should not exceed 4 m.

In exceptional cases, the pressure transmitter can also be installed above the measuring point. This is only valid for pure overpressure measurements.

Height differences between the diaphragm seal and the pressure transmitter can be corrected when installing the pressure transmitter. When applying a zero or elevation suppression, pay attention to the limits of the pressure transmitter.

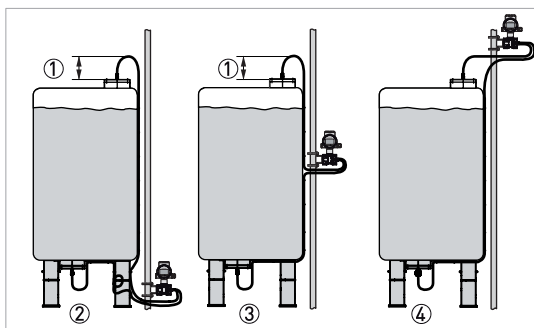

- ① Max. 80 mm
- ② Standard measurement setup also suitable for negative pressure applications
- ③ Alternative measurement setup for atmospheric pressure measurement
- ④ Measurement setup for overpressure applications only

## 2.3 Attaching the capillary tube

Due to its own weight, the fill fluid in the capillary tube is subject to physical inertia. If, for example, the fluid columns in the capillary tubes in measuring systems are exposed to a mechanical acceleration due to vibrations or impact, fluctuations in pressure occur in the system. These pressure fluctuations can result in an incorrect measuring signal. It is irrelevant whether or not an overpressure (process pressure) is acting on the diaphragm seal system. To measure the pressure smoothly in practice, the capillary tube must be firmly and securely routed and attached. Install and attach the capillary tube vibration-free and wind any excess length onto a ring with a diameter of approx. 30 cm.

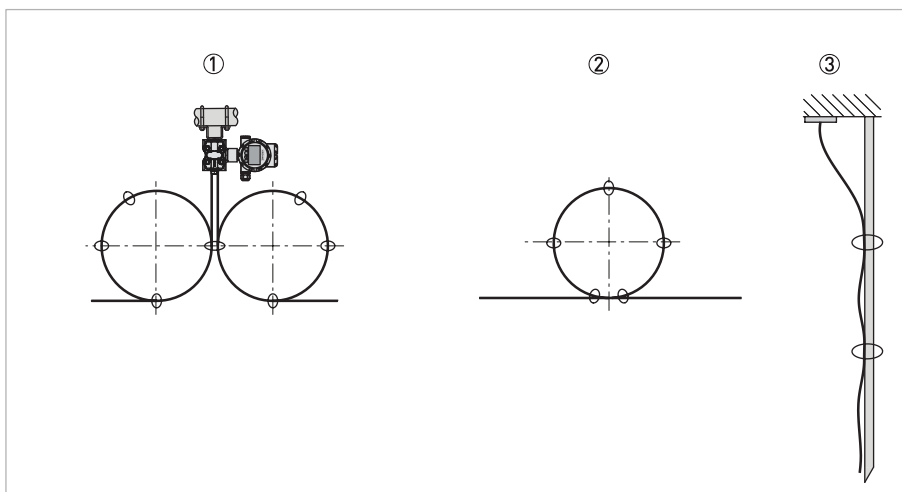

Figure 2-1: Attaching the capillary tube

- ① Attachment of capillary tube near the device
- ② Attachment of capillary tube on the line
- ③ Attachment of capillary tube without excess length

## 2.4 Use in hazardous areas

The ambient temperatures for the pressure transmitter may not exceed the permissible limits in hazardous areas (see supplementary manual of respective Ex-device). In the case of diaphragm seal systems with a flame arrester (for attachment in zone 0), the operating temperature for the pressure transmitter may not exceed 60°C. For more information see diaphragm seal for attachment in zone 0 (see enclosed data sheet)

## 3.1 Maintenance advice

In normal operating conditions, no maintenance of the diaphragm seal system is necessary. However, we do recommend annual recalibration. You can arrange for the diaphragm seal system to be sent back to the factory for service or inspection.

## 3.2 Returning the device to the manufacturer

### 3.2.1 General information

This device has been carefully manufactured and tested. If installed and operated in accordance with these operating instructions, it will rarely present any problems.

*Should you nevertheless need to return a device for inspection or repair, please pay strict attention to the following points:*

- *Due to statutory regulations on environmental protection and safeguarding the health and safety of the personnel, the manufacturer may only handle, test and repair returned devices that have been in contact with products without risk to personnel and environment.*
- *This means that the manufacturer can only service this device if it is accompanied by the following certificate (see next section) confirming that the device is safe to handle.*

*If the device has been operated with toxic, caustic, radioactive, flammable or water-endangering products, you are kindly requested:*

- *to check and ensure, if necessary by rinsing or neutralising, that all cavities are free from such dangerous substances,*
- *to enclose a certificate with the device confirming that it is safe to handle and stating the product used.*

### 3.2.2 Form (for copying) to accompany a returned device

*To avoid any risk for our service personnel, this form has to be accessible from outside of the packaging with the returned device.*

Company:		Address:	
Department:		Name:	
Tel. no.:		Fax no. and/or Email address:	
Manufacturer's order no. or serial no.:			
The device has been operated with the following medium:			
This medium is:	<input type="checkbox"/>	radioactive	
	<input type="checkbox"/>	water-hazardous	
	<input type="checkbox"/>	toxic	
	<input type="checkbox"/>	caustic	
	<input type="checkbox"/>	flammable	
	<input type="checkbox"/>	We checked that all cavities in the device are free from such substances.	
	<input type="checkbox"/>	We have flushed out and neutralized all cavities in the device.	
We hereby confirm that there is no risk to persons or the environment through any residual media contained in the device when it is returned.			
Date:		Signature:	
Stamp:			

### 3.3 Disposal

*Disposal must be carried out in accordance with legislation applicable in your country.*

#### Separate collection of WEEE (Waste Electrical and Electronic Equipment) in the European Union:



According to the directive 2012/19/EU, the monitoring and control instruments marked with the WEEE symbol and reaching their end-of-life **must not be disposed of with other waste**. The user must dispose of the WEEE to a designated collection point for the recycling of WEEE or send them back to our local organisation or authorised representative.



## 4.1 Diaphragm seals for general applications

### 4.1.1 Flange diaphragm seals

Design	
Base body	Volume-reduced diaphragm base
Base body material	Stainless steel 316L (1.4404 / 1.4435)
Diaphragm	Front-flush diaphragm, welded by laser
Material wetted parts (Diaphragm and raised face)	316L, Hastelloy C-276, tantalum, titanium grade 2, Monel 400, Duplex, 316L with PTFE film, 316L with PFA coating, 316L with gold coating

Process connection	
Design	Flanged connections in accordance with EN 1092-1 and ASME B16.5
Nominal pressure / nominal size:	See dimensions
The seal is not included in delivery.	

Sealing faces according to	
EN 1092-1 - Form B1, B2	
ASME B16.5 - RF 125-250AA, RFSF	
Diaphragm made of special materials only available with sealing face Form B2 and RFSF	

Connection to pressure transmitter	
Direct connection (with cooling fins, without cooling fins or as 90° angle design) or connection with capillary tube	
Material	Stainless steel 304 (1.4301)

Fill fluid	
Silicone oil, silicone-free synthetic oil, vacuum and high-temperature oil, halocarbon oil, Glycerin/water mixture	

Temperature error	
We can supply you with a temperature error calculation protocol upon request	

Weight	
See dimensions	

Approvals and certificates	
Connection to zone 0	with flame arrester
Registration marking	IIG IIC according to PTB 03 ATEX 4032 X

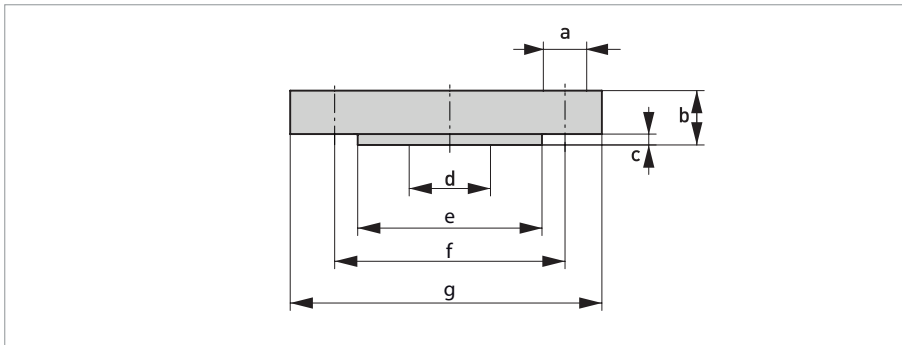

Dimensions (mm) EN 1092-1										
DN	PN	a	b	c	d	e	f	g	Number of holes	weight [kg]
50	10/40	18	20	2	51	102	125	165	4	3.2
50	63	22	26	2	51	102	135	180	4	4.1
80	10/40	18	24	2	86	138	160	200	8	5
100	10/16	18	20	2	86	158	180	220	8	6
100	25/40	18	24	2	86	162	190	235	8	10

Dimensions (mm) ASME B16.5										
Inch	Class	a	b	c	d	e	f	g	Number of holes	weight [kg]
2	150	19	19.5	2	51	92	120.7	150	4	3.2
2	300	19	22.7	2	51	92	127	165	8	4.1
3	150	19	24.3	2	86	127	152.4	190	4	5.2
3	300	22	29	2	86	127	168.3	210	8	5.7
4	150	19	24.3	2	86	158	190.5	230	8	7
4	300	22	32.2	2	86	158	200	255	8	11

*Others dimension on request.*

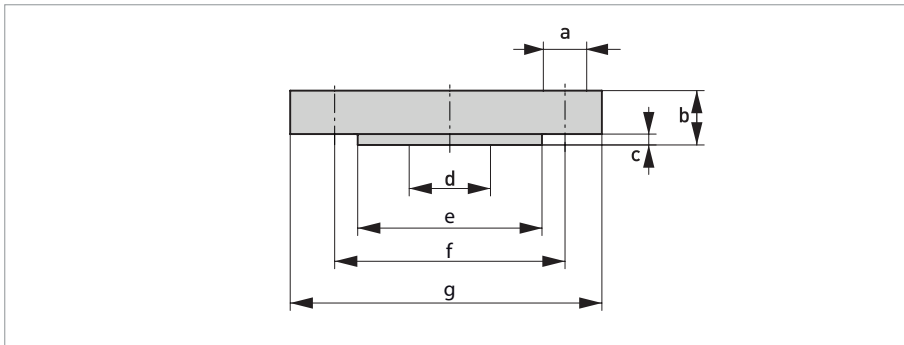

Dimensions (inch) EN 1092-1

DN	PN	a	b	c	d	e	f	g	Number of holes	weight [lb]
50	10/40	0.71	0.79	0.08	2.01	4.02	4.92	6.50	4	7.05
50	63	0.87	1.02	0.08	2.01	4.02	5.31	7.09	4	9.04
80	10/40	0.71	0.94	0.08	3.39	5.43	6.30	7.87	8	11.03
100	10/16	0.71	0.79	0.08	3.39	6.22	7.09	8.66	8	13.23
100	25/40	0.71	0.94	0.08	3.39	6.38	7.48	9.25	8	22.05

Dimensions (inch) ASME B16.5

Inch	Class	a	b	c	d	e	f	g	Number of holes	weight [lb]
2	150	0.75	0.77	0.08	2.01	3.62	4.75	5.91	4	7.05
2	300	0.75	0.89	0.08	2.01	3.62	5.00	6.50	8	9.04
3	150	0.75	0.96	0.08	3.39	5.00	6.00	7.48	4	11.46
3	300	0.87	1.14	0.08	3.39	5.00	6.63	8.27	8	12.57
4	150	0.75	0.96	0.08	3.39	6.22	7.50	9.06	8	15.43
4	300	0.87	1.27	0.08	3.39	6.22	7.87	10.0	8	24.25

*Others dimension on request.*

## 4.1.2 Flange diaphragm seal with extension

Design	
Base body	Volume-reduced diaphragm base
Base body material	Stainless steel 316L (1.4404 / 1.4435)
Diaphragm	Flat Diaphragm
Material wetted parts (Diaphragm and raised face)	316L, Hastelloy C-276, Tantal, 316L with PFA coating

Process connection	
Design	Flange diaphragm seal with extension Flanged connections in accordance with EN 1092-1 and ASME B16.5 with welded tube body
Tube body lengths	50 mm, 100 mm, 150 mm and 200 mm Special lengths on request
Nominal pressure / nominal size	See dimensions
The seal is not included in delivery.	

Sealing faces according to	
EN 1092-1 - Form B1, B2	
ASME B16.5 - RF 125-250AA, RFSF	
Diaphragm made of special materials only available with raised face Form B2 and RFSF	

Connection to pressure transmitter	
Direct connection (with cooling fins, without cooling fins or as 90° angle design) or connection with capillary tube	
Material	Stainless steel 304 (1.4301)

Fill fluid	
Silicone oil, silicone-free synthetic oil, vacuum and high-temperature oil, halocarbon oil, Glycerin/water mixture	

Temperature error	
We can supply you with a temperature error calculation protocol upon request	

Weight	
DN 80	approx. 6.5 kg
2" Class 300	approx. 5.1 kg
Others weights on request	

Approvals and certificates	
Connection to zone 0	with flame arrester
Registration marking	IIG IIC according to PTB 03 ATEX 4032 X

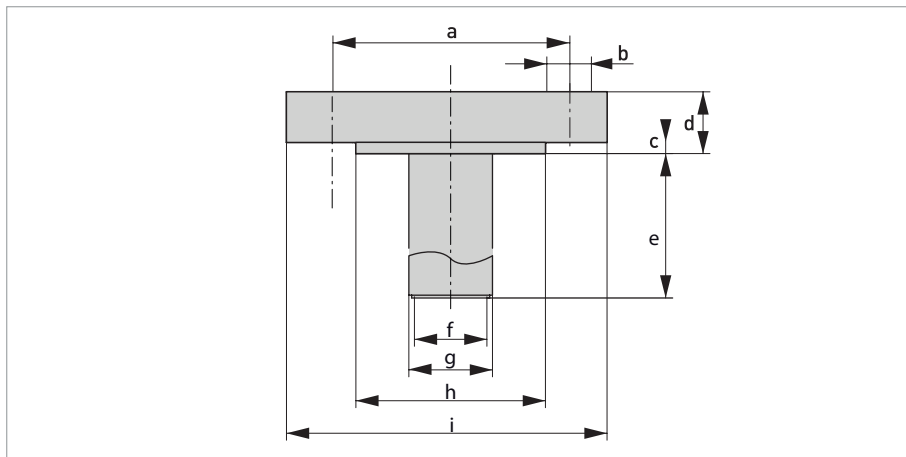

Dimensions (mm) EN 1092-1

DN	PN	a	b	c	d	e	f	g	h	i	Number of holes
50	10/40	125	18	2	20	Indicate when ordering	42	48.3	102	165	4
80	10/40	160	18	2	24		72	76	138	200	8
100	10/16	180	18	2	20		86	94	158	220	8
100	25/40	190	22	2	24		86	94	162	235	8

Dimensions (mm) ASME B 16.5

Inch	Class	a	b	c	d	e	f	g	h	i	Number of holes
2	150	120.7	19	2	19.5	Indicate when ordering	46	48.3	92	150	4
2	300	127	19	2	22.7		46	48.3	92	165	8
3	150	152.4	19	2	24.3		65	76	127	190	4
3	300	168.3	22	2	29		65	76	127	210	8
4	150	190.5	19	2	24.3		86	94	158	230	8
4	300	200	22	2	32.2		86	94	158	255	8

*Others dimension on request.*

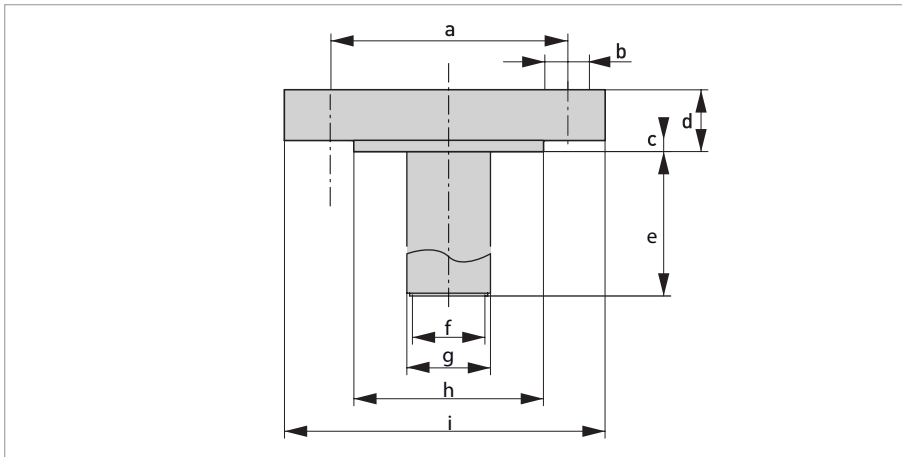

Dimensions (inch) EN 1092-1											
DN	PN	a	b	c	d	e	f	g	h	i	Number of holes
50	10/40	4.92	0.71	0.08	0.79	Indicate when ordering	1.65	1.90	4.02	5.91	4
80	10/40	6.30	0.71	0.08	0.94		2.83	2.99	5.43	7.87	8
100	10/16	7.09	0.71	0.08	0.79		3.39	3.70	6.22	8.66	8
100	25/40	7.48	0.87	0.08	0.94		3.39	3.70	6.38	9.25	8

Dimensions (inch) ASME B 16.5											
Inch	Class	a	b	c	d	e	f	g	h	i	Number of holes
2	150	4.75	0.75	0.08	0.77	Indicate when ordering	1.81	1.90	3.62	5.91	4
2	300	5.00	0.75	0.08	0.89		1.81	1.90	3.62	6.50	8
3	150	6.00	0.75	0.08	0.96		2.56	2.99	5.00	7.48	4
3	300	6.63	0.87	0.08	1.14		2.56	2.99	5.00	8.27	8
4	150	7.50	0.75	0.08	0.96		3.39	3.70	6.22	9.06	8
4	300	7.87	0.87	0.08	1.27		3.39	3.70	6.22	10.0 4	8

*Others dimensions on request.*

## 4.2 Diaphragm seals for special applications

### 4.2.1 Threaded diaphragm seals and open measuring flange

Design		
Base body	Volume-reduced diaphragm base	
Base body material	Stainless Steel 316L (1.4404)	
Diaphragm	Flat diaphragm	
Material wetted parts	Diaphragm	316L, Hastelloy C-276, Tantal, 316L with PTFE-foil
	Bottom flange	Stainless steel 316L (1.4404), PVDF

Process connection		
Design	Threaded	<ul style="list-style-type: none"> <li>• G1/2 B (male)</li> <li>• 1/2 NPT (female)</li> <li>• 1/2 NPT (male)</li> </ul>
	Open measuring flange	<ul style="list-style-type: none"> <li>• DN25 Form B2</li> <li>• DN50 Form B2</li> <li>• 1" RFSF</li> <li>• 2" RFSF</li> </ul>

Sealing
NBR, FKM, PTFE

Connection to pressure transmitter	
Direct connection (with cooling fins, without cooling fins or as 90° angle design) or connection with capillary tube	
Material	Stainless steel 304 (1.4301)

Fill fluid
Silicone oil, silicone-free synthetic oil, vacuum and high-temperature oil, halocarbon oil, Glycerin/water mixture

Temperature error
We can supply you with a temperature error calculation protocol upon request

Weight	
G1/2 B, PN 100	approx. 1.5 kg
G1/2 B, PN 250	approx. 2.1 kg
DN25, PN 10-40	approx. 2.5 kg
Others weights on request	

Approvals and certificates	
Connection to zone 0	with flame arrester
Registration marking	IIG IIC according to PTB 03 ATEX 4032 X

**Threaded diaphragm seal**

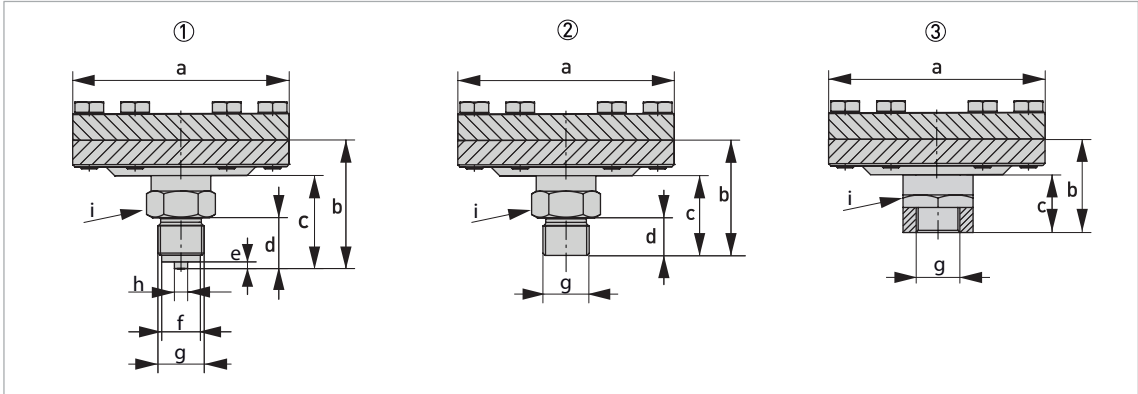

- ① Threaded diaphragm seal G1/2 B, EN837-1
- ② Threaded diaphragm seal ANSI 1/2 NPT (male thread)
- ③ Threaded diaphragm seal ANSI 1/2 NPT (female thread)

Dimensions (mm)									
	a	b	c	d	e	f	g	h	i
①	98	58	42	23	3	Ø17.5	G1/2 B	Ø6	WS27
②	98	55	39	20	-	-	1/2 NPT	-	WS27
③	98	42	26	-	-	-	1/2 NPT	-	WS 32

Dimensions (inch)									
	a	b	c	d	e	f	g	h	i
①	3.86	2.28	1.65	0.91	0.12	Ø0.69	G1/2 B	Ø0.24	WS27
②	3.86	2.17	1.54	0.79	-	-	1/2 NPT	-	WS27
③	3.86	1.65	1.02	-	-	-	1/2 NPT	-	WS 32

*Others dimension on request.*



## Diaphragm seal with open measuring flange

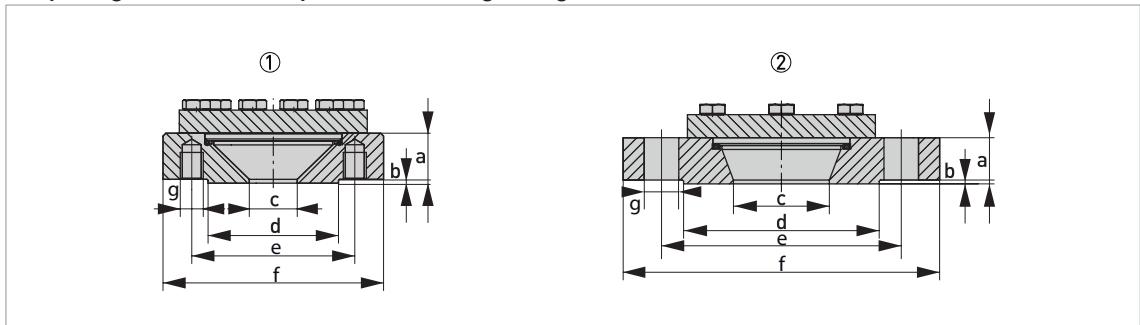

- ① Diaphragm seal with open measuring flange DN25 / 1"  
 ② Diaphragm seal with open measuring flange DN50 / 2"

Dimensions (mm) EN 1092-1

DN	PN	a	b	c	d	e	f	g	h	Number of holes
25	10/40	26	2	27	68	85	115	M12	-	4
50	10/40	26	2	51	102	125	165	-	18	4

Dimensions (mm) ASME B16.5

Inch	Class	a	b	c	d	e	f	g	h	Number of holes
1	150	32	2	30	51	79.4	110	M12	-	4
1	300	32	2	30	51	88.9	125	M16	-	4
2	150	24	2	51	92	120.7	150	M16	-	4

Dimensions (inch) EN 1092-1

DN	PN	a	b	c	d	e	f	g	h	Number of holes
25	10/40	1.02	0.08	1.06	2.68	3.35	4.53	1/2	-	4
50	10/40	1.02	0.08	2.01	4.02	4.92	6.50	-	0.71	4

Dimensions (inch) ASME B 16.5

Inch	Class	a	b	c	d	e	f	g	h	Number of holes
1	150	1.26	0.08	1.18	2.01	3.13	4.33	1/2	-	4
1	300	1.02	0.08	1.18	2.01	3.5	4.92	5/8	-	4
2	150	0.94	0.08	2.01	3.62	4.75	5.91	5/8	-	4

*Others dimension on request.*

## 5.1 OPTIBAR DSP

## 5.1.1 OPTIBAR DSP 3000

*The characters of the order code highlighted in light grey describe the standard.*

**Diaphragm seal for general applications as flange design for installation on pressure transmitter). Optionally available with extension.**

VGKF	4	Approval
	0	Without
	1	Attachment to zone 0 with flame arrester
		<b>Process connection</b>
	B2	Flange DN50 PN10/40 Form B1; EN 1092-1
	AG	Flange DN50 PN10/40 Form B2; EN 1092-1
	WK	Flange DN50 PN63 Form B1; EN 1092-1
	WB	Flange DN50 PN63 Form B2; EN 1092-1
	B5	Flange DN80 PN10/40 Form B1; EN 1091-1
	B1	Flange DN80 PN10/40 Form B2; EN 1091-1
	CC	Flange DN100 PN10/16 Form B1; EN 1092-1
	LG	Flange DN100 PN10/16 Form B2; EN 1092-1
	CD	Flange DN100 PN25/40 Form B1; EN 1092-1
	LE	Flange DN100 PN25/40 Form B2; EN 1092-1
	CA	Flange 2" class 150 RF 125...250 AA, ASME B16.5
	BK	Flange 2" class 150 RFSF, ASME B16.5
	L8	Flange 2" class 300 RF 125...250 AA, ASME B16.5
	KC	Flange 2" class 300 RFSF, ASME B16.5
	CB	Flange 3" class 150 RF 125...250 AA, ASME B16.5
	BY	Flange 3" class 150 RFSF, ASME B16.5
	B6	Flange 3" class 300 RF 125...250 AA, ASME B16.5
	CM	Flange 3" class 300 RFSF, ASME B16.5
	BB	Flange 4" class 150 RF 125...250 AA, ASME B16.5
	GG	Flange 4" class 150 RFSF, ASME B16.5
	BA	Flange 4" class 300 RF 125...250 AA, ASME B16.5
	T1	Flange 4" class 300 RFSF, ASME B16.5
	ZZ	Customer specific process connection

<b>Material wetted parts (Diaphragm + raised face)</b>	
S	316L (1.4401/1.4435)
P	316L (1.4404/1.4435) with PTFE film; highly vacuum resistant
F	316L (1.4404/1.4435) with PFA coating
H	Hastelloy C-276 (2.4819)
T	Tantalum
G	Titan Grade 2 (3.7035/34)
M	Monel 400 (2.4360)
D	Duplex (1.4462)
A	Gold coating 6 µm (Flange DN50; DN80; 2", 3")
Z	Customer-specific material
<b>Tube body length high-pressure side</b>	
SX	0 mm / 0"; 316L
S1	50 mm / 1.97"; 316L
S2	100 mm / 3.94"; 316L
S3	150 mm / 5.91"; 316L
S4	200 mm / 7.87"; 316L
S5	300 mm / 11.81"; 316L
S6	500 mm / 19.70"; 316L
ZZ	Customer-specific tube body length
<b>Fill fluid</b>	
S	Silicone oil: -50...+300°C / -58...+572°F
F	Silicone-free synthetic oil (FDA, food grade) -50...+230°C / -58...+446°F
T	Vacuum and high-temperature oil -10...+400°C / +14...+752°F
H	Halocarbon oil -30...+190°C / -22...+374°F (Oxygen +60°C / +140°F)
G	Glycerin/water mixture -30...+110°C / -22...+230°F
Z	Customer-specific fill fluid
<b>Negative pressure service (&lt;0 bar relative)</b>	
0	Without
1	Negative pressure
2	Vacuum
<b>Attachment specification</b>	
1	Direct (max. +150°C / +302°F)
2	Direct with cooling element; 30 mm / 1.18" (>+150...+180°C / +302...+356°F)
3	Direct with cooling element; 98 mm / 3.86" (>+150...+250°C / +302...+482°F)
W	Direct with 90° angle design; 90 mm / 3.54" (max. +180°C / +356°F)
K	Capillary tube (max. +400°C / +752°F)



## 5.1.2 OPTIBAR DSP 2000

The characters of the order code highlighted in light grey describe the standard.

**Diaphragm seal for special applications with threaded connection or open measuring flange for installation on pressure transmitter.**

<b>VGKG</b>	<b>4</b>	<b>Approval</b>
	0	Without
	1	Attachment to zone 0 with flame arrester
		<b>Process connection</b>
	A	Thread G1/2 B, EN 837-1; PN100; 316L
	B	Thread G1/2 B, EN 837-1; PN250; 316L
	F	Thread 1/2-NPT-Female; PN100; 316L
	G	Thread 1/2-NPT-Female; PN250; 316L
	M	Thread 1/2-NPT-Male; PN100; 316L
	N	Thread 1/2-NPT-Male; PN250; 316L
	K	Open measuring flange DN25 Form B1; EN1092-1; PN10-40; 316L
	L	Open measuring flange 1" RF; ASME B16.5; Class 300; 316L
	1	Thread G1/2 B; EN 837-1; PN16; PVDF
	4	Open measuring flange DN25 Form B2; EN 1092-1; PN16; PVDF
	5	Open measuring flange DN50 Form B2; EN 1092-1; PN16; PVDF
	7	Open measuring flange 1" RFSF; ASME B16.5; Class 150; PVDF
	8	Open measuring flange 2" RFSF; ASME B16.5; Class 150; PVDF
	Z	Customer specific process connection
		<b>Material wetted parts (Diaphragm)</b>
	S	316L (1.4401/1.4435)
	P	316L (1.4404/1.4435) with PTFE film; highly vacuum resistant
	H	Hastelloy C-276 (2.4819)
	T	Tantalum
	Z	Customer-specific material
		<b>Sealing</b>
	N	NBR; -25...+120°C / -13...+248°F
	V	FKM; -40...+200°C / -40...+392°F
	P	PTFE; -100...+250°C / -148...+482°F
		<b>Flushing hole</b>
	0	Without
	2	With 2x 1/4 NPT flushing holes (including plug)





## 5.2 OPTIBAR DSD

## 5.2.1 OPTIBAR DSD 3100

*The characters of the order code highlighted in light grey describe the standard.*

**Diaphragm seal for general applications as flange design for installation on differential pressure transmitter (direct attachment). Optionally available with extensions.**

VGKD	4	Approval
	0	Without
	1	Attachment to zone 0 with flame arrester
		<b>Process connection</b>
	B2	Flange DN50 PN10/40 Form B1; EN 1092-1
	AG	Flange DN50 PN10/40 Form B2; EN 1092-1
	WK	Flange DN50 PN63 Form B1; EN 1092-1
	WB	Flange DN50 PN63 Form B2; EN 1092-1
	B5	Flange DN80 PN10/40 Form B1; EN 1091-1
	B1	Flange DN80 PN10/40 Form B2; EN 1091-1
	CC	Flange DN100 PN10/16 Form B1; EN 1092-1
	LG	Flange DN100 PN10/16 Form B2; EN 1092-1
	CD	Flange DN100 PN25/40 Form B1; EN 1092-1
	LE	Flange DN100 PN25/40 Form B2; EN 1092-1
	CA	Flange 2" class 150 RF 125...250 AA, ASME B16.5
	BK	Flange 2" class 150 RFSF, ASME B16.5
	L8	Flange 2" class 300 RF 125...250 AA, ASME B16.5
	KC	Flange 2" class 300 RFSF, ASME B16.5
	CB	Flange 3" class 150 RF 125...250 AA, ASME B16.5
	BY	Flange 3" class 150 RFSF, ASME B16.5
	B6	Flange 3" class 300 RF 125...250 AA, ASME B16.5
	CM	Flange 3" class 300 RFSF, ASME B16.5
	BB	Flange 4" class 150 RF 125...250 AA, ASME B16.5
	GG	Flange 4" class 150 RFSF, ASME B16.5
	BA	Flange 4" class 300 RF 125...250 AA, ASME B16.5
	T1	Flange 4" class 300 RFSF, ASME B16.5
	ZZ	Customer specific process connection
		<b>Material wetted parts (Diaphragm + raised face)</b>
	S	316L (1.4401/1.4435)
	P	316L (1.4404/1.4435) with PTFE film; highly vacuum resistant
	F	316L (1.4404/1.4435) with PFA coating
	H	Hastelloy C-276 (2.4819)
	T	Tantalum





## 5.2.2 OPTIBAR DSD 3110

The characters of the order code highlighted in light grey describe the standard.

**Diaphragm seal for general applications as flange design for installation on differential pressure transmitter (capillary tube attachment). Optionally available with extension.**

VGKH	4	Approval
	0	Without
	1	Attachment to zone 0 with flame arrester
		<b>Process connection</b>
	B2	Flange DN50 PN10/40 Form B1; EN 1092-1
	AG	Flange DN50 PN10/40 Form B2; EN 1092-1
	WK	Flange DN50 PN63 Form B1; EN 1092-1
	WB	Flange DN50 PN63 Form B2; EN 1092-1
	B5	Flange DN80 PN10/40 Form B1; EN 1091-1
	B1	Flange DN80 PN10/40 Form B2; EN 1091-1
	CC	Flange DN100 PN10/16 Form B1; EN 1092-1
	LG	Flange DN100 PN10/16 Form B2; EN 1092-1
	CD	Flange DN100 PN25/40 Form B1; EN 1092-1
	LE	Flange DN100 PN25/40 Form B2; EN 1092-1
	CA	Flange 2" class 150 RF 125...250 AA, ASME B16.5
	BK	Flange 2" class 150 RFSF, ASME B16.5
	L8	Flange 2" class 300 RF 125...250 AA, ASME B16.5
	KC	Flange 2" class 300 RFSF, ASME B16.5
	CB	Flange 3" class 150 RF 125...250 AA, ASME B16.5
	BY	Flange 3" class 150 RFSF, ASME B16.5
	B6	Flange 3" class 300 RF 125...250 AA, ASME B16.5
	CM	Flange 3" class 300 RFSF, ASME B16.5
	BB	Flange 4" class 150 RF 125...250 AA, ASME B16.5
	GG	Flange 4" class 150 RFSF, ASME B16.5
	BA	Flange 4" class 300 RF 125...250 AA, ASME B16.5
	T1	Flange 4" class 300 RFSF, ASME B16.5
	ZZ	Customer specific process connection
		<b>Material wetted parts (Diaphragm + raised face)</b>
	S	316L (1.4401/1.4435)
	P	316L (1.4404/1.4435) with PTFE film; highly vacuum resistant
	F	316L (1.4404/1.4435) with PFA coating
	H	Hastelloy C-276 (2.4819)
	T	Tantalum
	G	Titan Grade 2 (3.7035/34)
	M	Monel 400 (2.4360)
	D	Duplex (1.4462)
	A	Gold coating 6 µm (Flange DN50; DN80; 2", 3")
	Z	Customer-specific material

<b>Fill fluid</b>	
S	Silicone oil: -50...+300°C / -58...+572°F
F	Silicone-free synthetic oil (FDA, food grade) -50...+230°C / -58...+446°F
T	Vacuum and high-temperature oil -10...+400°C / +14...+752°F
H	Halocarbon oil -30...+190°C / -22...+374°F (Oxygen +60°C / +140°F)
G	Glycerin/water mixture -30...+110°C / -22...+230°F
Z	Customer-specific fill fluid
<b>Negative pressure service (&lt;0 bar relative)</b>	
0	Without
1	Negative pressure
2	Vacuum
<b>Attachment high-pressure side</b>	
S	Capillary tube with stainless steel spiral protective tube and handhold
P	Capillary tube with stainless steel spiral protective tube (PVC coating) and handhold
<b>Capillary tube length high-pressure side</b>	
Stainless steel spiral protective tube	
S0	Standard 1.6 m / 5.25 ft.
SA	2.0 m / 6.56 ft.
SB	2.5 m / 8.20 ft.
SE	4.0 m / 13.12 ft.
SG	5.0 m / 16.40 ft.
SK	6.0 m / 19.68 ft.
SL	8.0 m / 26.25 ft.
SM	10.0 m / 32.81 ft.
Stainless steel spiral protective tube, PVC coating	
P0	Standard 1.6 m / 5.25 ft.
pA	2.0 m / 6.56 ft.
PB	2.5 m / 8.20 ft.
PE	4.0 m / 13.12 ft.
PG	5.0 m / 16.40 ft.
PK	6.0 m / 19.68 ft.
PL	8.0 m / 26.25 ft.
PM	10.0 m / 32.81 ft.
ZZ	Customer-specific capillary tube length



## 5.2.3 OPTIBAR DSD 3210

*The characters of the order code highlighted in light grey describe the standard.*

**Diaphragm seal for general applications as flange design for installation on differential pressure transmitter (direct and capillary tube attachment). Optionally available with extension.**

VGKE	4	Approval
	0	Without
	1	Attachment to zone 0 with flame arrester
		<b>Process connection</b>
	B2	Flange DN50 PN10/40 Form B1; EN 1092-1
	AG	Flange DN50 PN10/40 Form B2; EN 1092-1
	WK	Flange DN50 PN63 Form B1; EN 1092-1
	WB	Flange DN50 PN63 Form B2; EN 1092-1
	B5	Flange DN80 PN10/40 Form B1; EN 1091-1
	B1	Flange DN80 PN10/40 Form B2; EN 1091-1
	CC	Flange DN100 PN10/16 Form B1; EN 1092-1
	LG	Flange DN100 PN10/16 Form B2; EN 1092-1
	CD	Flange DN100 PN25/40 Form B1; EN 1092-1
	LE	Flange DN100 PN25/40 Form B2; EN 1092-1
	CA	Flange 2" class 150 RF 125...250 AA, ASME B16.5
	BK	Flange 2" class 150 RFSF, ASME B16.5
	L8	Flange 2" class 300 RF 125...250 AA, ASME B16.5
	KC	Flange 2" class 300 RFSF, ASME B16.5
	CB	Flange 3" class 150 RF 125...250 AA, ASME B16.5
	BY	Flange 3" class 150 RFSF, ASME B16.5
	B6	Flange 3" class 300 RF 125...250 AA, ASME B16.5
	CM	Flange 3" class 300 RFSF, ASME B16.5
	BB	Flange 4" class 150 RF 125...250 AA, ASME B16.5
	GG	Flange 4" class 150 RFSF, ASME B16.5
	BA	Flange 4" class 300 RF 125...250 AA, ASME B16.5
	T1	Flange 4" class 300 RFSF, ASME B16.5
	ZZ	Customer specific process connection
		<b>Material wetted parts (Diaphragm + raised face)</b>
	S	316L (1.4401/1.4435)
	P	316L (1.4404/1.4435) with PTFE film; highly vacuum resistant
	F	316L (1.4404/1.4435) with PFA coating
	H	Hastelloy C-276 (2.4819)
	T	Tantalum
	G	Titan Grade 2 (3.7035/34)
	M	Monel 400 (2.4360)
	D	Duplex (1.4462)
	A	Gold coating 6 µm (Flange DN50; DN80; 2", 3")
	Z	Customer-specific material





## 5.2.4 OPTIBAR DSD 3220

The characters of the order code highlighted in light grey describe the standard.

**Diaphragm seal for general applications as flange design for installation on differential pressure transmitter (2x capillary tube attachment). Optionally available with extension.**

VGKK	4	Approval
	0	Without
	1	Attachment to zone 0 with flame arrester
		<b>Process connection</b>
	B2	Flange DN50 PN10/40 Form B1; EN 1092-1
	AG	Flange DN50 PN10/40 Form B2; EN 1092-1
	WK	Flange DN50 PN63 Form B1; EN 1092-1
	WB	Flange DN50 PN63 Form B2; EN 1092-1
	B5	Flange DN80 PN10/40 Form B1; EN 1091-1
	B1	Flange DN80 PN10/40 Form B2; EN 1091-1
	CC	Flange DN100 PN10/16 Form B1; EN 1092-1
	LG	Flange DN100 PN10/16 Form B2; EN 1092-1
	CD	Flange DN100 PN25/40 Form B1; EN 1092-1
	LE	Flange DN100 PN25/40 Form B2; EN 1092-1
	CA	Flange 2" class 150 RF 125...250 AA, ASME B16.5
	BK	Flange 2" class 150 RFSF, ASME B16.5
	L8	Flange 2" class 300 RF 125...250 AA, ASME B16.5
	KC	Flange 2" class 300 RFSF, ASME B16.5
	CB	Flange 3" class 150 RF 125...250 AA, ASME B16.5
	BY	Flange 3" class 150 RFSF, ASME B16.5
	B6	Flange 3" class 300 RF 125...250 AA, ASME B16.5
	CM	Flange 3" class 300 RFSF, ASME B16.5
	BB	Flange 4" class 150 RF 125...250 AA, ASME B16.5
	GG	Flange 4" class 150 RFSF, ASME B16.5
	BA	Flange 4" class 300 RF 125...250 AA, ASME B16.5
	T1	Flange 4" class 300 RFSF, ASME B16.5
	ZZ	Customer specific process connection
		<b>Material wetted parts (Diaphragm + raised face)</b>
	S	316L (1.4401/1.4435)
	P	316L (1.4404/1.4435) with PTFE film; highly vacuum tight
	F	316L (1.4404/1.4435) with PFA coating
	H	Hastelloy C-276 (2.4819)
	T	Tantalum
	G	Titan Grade 2 (3.7035/34)
	M	Monel 400 (2.4360)
	D	Duplex (1.4462)
	A	Gold coating 6 µm (Flange DN50; DN80; 2"; 3")
	Z	Customer-specific material



		<b>Fill fluid</b>	
S		Silicone oil: -50...+300°C / -58...+572°F	
F		Silicone-free synthetic oil (FDA, food grade) -50...+230°C / -58...+446°F	
T		Vacuum and high-temperature oil -10...+400°C / +14...+752°F	
H		Halocarbon oil -30...+190°C / -22...+374°F (Oxygen +60°C / +140°F)	
G		Glycerin/water mixture -30...+110°C / -22...+230°F	
Z		Customer-specific fill fluid	
		<b>Negative pressure service (&lt;0 bar relative)</b>	
0		Without	
1		Negative pressure	
2		Vacuum	
		<b>Attachment specification high and low-pressure side</b>	
S		Capillary tube with stainless steel spiral protective tube and handhold	
P		Capillary tube with stainless steel spiral protective tube (PVC coating) and handhold	
		<b>Capillary tube length high and low-pressure side</b>	
		Stainless steel spiral protective tube	
S0		Standard 1.6 m / 5.25 ft.	
SA		2.0 m / 6.56 ft.	
SB		2.5 m / 8.20 ft.	
SE		4.0 m / 13.12 ft.	
SG		5.0 m / 16.40 ft.	
SK		6.0 m / 19.68 ft.	
SL		8.0 m / 26.25 ft.	
SM		10.0 m / 32.81 ft.	
		Stainless steel spiral protective tube, PVC coating	
P0		Standard 1.6 m / 5.25 ft.	
pA		2.0 m / 6.56 ft.	
PB		2.5 m / 8.20 ft.	
PE		4.0 m / 13.12 ft.	
PG		5.0 m / 16.40 ft.	
PK		6.0 m / 19.68 ft.	
PL		8.0 m / 26.25 ft.	
PM		10.0 m / 32.81 ft.	
ZZ		Customer-specific capillary tube length	



## 5.3 Accessories

### 5.3.1 Flushing ring

The characters of the order code highlighted in light grey describe the standard.

<b>VGKX</b>	<b>4</b>	<b>Process connection</b>	
		A	DN50 PN16 up to 400 Form B1
		B	DN50 PN16 up to 400 Form B2
		D	DN80 PN16 up to 400 Form B1
		E	DN80 PN16 up to 400 Form B2
		G	DN100 PN16 up to 400 Form B1
		H	DN100 PN16 up to 400 Form B2
		M	2" class 150 up to 1500 RF
		N	2" class 150 up to 1500 RFSF
		P	3" class 150 up to 1500 RF
		R	3" class 150 up to 1500 RFSF
		T	4" class 150 up to 1500 RF
		U	4" class 150 up to 1500 RFSF
		Z	Customer specific process connection
		<b>Flushing hole</b>	
		1	2x Female thread G1/4
		C	2x Female thread G1/4 incl. plug
		3	2x Female thread 1/4-18 NPT
		H	2x Female thread 1/4-18 NPT incl. plug
		Z	Customer-specific flushing hole
		<b>Material wetted parts</b>	
		0	316L (1.4404/1.4435)
		Z	Customer-specific material
<b>VGKX</b>	<b>4</b>		

