

Flow Measurement

SITRANS F US InLine

Transmitter SITRANS FUS060

Overview



SITRANS FUS060 is a transit time based transmitter designed for ultrasonic flowmetering with dedicated sensors in the FUS in-line series up to DN 3000. SITRANS FUS060 is engineered for high performance and is suitable for 1-path, 2-path and 4-path flowmeters.

Benefits

- Superior signal resolution for optimum turn down ratio
- Simple menu-based local operation with two-line display and four optical input elements, for unlimited use in potentially explosive atmospheres
- Self-monitoring and diagnostic
- Operate up to 4 paths
- ATEX II 2 G Ex dem [ia/ib] IIC T6/T4/T3 Gb
- Remote installation up to 120 m from sensor
- 1 analog output (4 to 20 mA) standard with HART-protocol, 1 digital frequency or pulse output, 1 relay output for limit, alarms, flow direction
- PROFIBUS PA Profile 2, 1 digital frequency or pulse output

Design

The transmitter type FUS060 is designed for remote installation in non-hazardous or hazardous areas.

The transmitter is designed for use in a flowmeter system together with sensors type SONOKIT, SONO 3300 and SONO 3100.

The FUS060 is ordered as part of a complete flowmeter system. It can be ordered separately as spare part and manually programmed with the sensor data.

Application

The main application for flowmeters with the transmitter SITRANS FUS060 is measurement volume of flow within the general, petrochemical and chemical industries, power engineering and water and waste water, as well as various types of oils and liquid gases.

Integration

The transmitter output is often used as input for an automation system or as input for systems of remote reading.

The SITRANS FUS060 transmitter offers current, pulse and relay outputs as standard output functions and supports HART or Profibus PA communication.

The settings of the transmitter output functions are individually programmed via keypad and display menu.

Function

Displays and keypad

Operation of the SITRANS FUS060 transmitter can be carried out using:

- Keypad and display unit
- HART communicator
- PC/laptop and SIMATIC PDM software via HART communication
- PC/laptop and SIMATIC PDM software using PROFIBUS PA communication

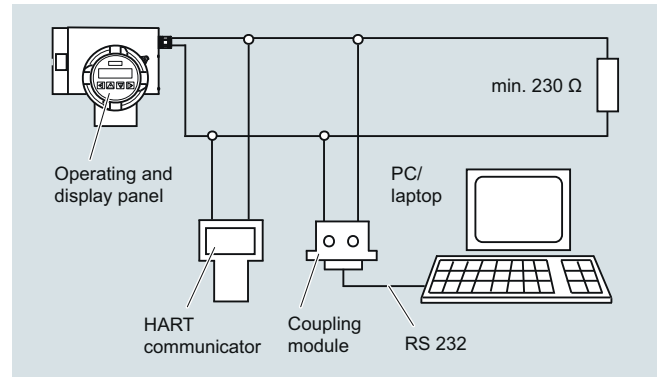

HART communication

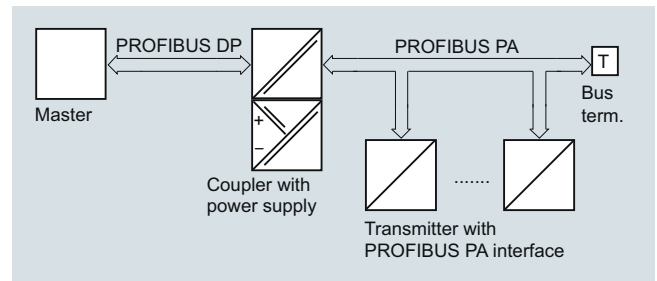

PROFIBUS PA communication

The operating and display panel permits simple operation without supplementary equipment. It is not necessary to open the housing. All changes to a setting can therefore also be carried out in the potentially explosive atmosphere.

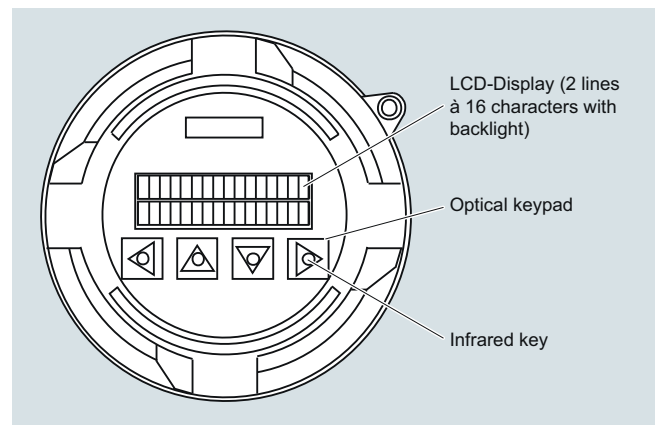

Operating and display panel

The individual functions and parameters are selected using a hierarchical, multi-language input menu and four infrared keys. The parameters can be specifically selected and modified using codes, e.g.:

- Operating parameters such as measuring range, physical dimensions, device information
- Limits for flow, totalizer, ultrasonic velocity or ultrasonic amplitude
- Noise suppression using damping, error stages and hysteresis
- Display parameters (freely-configurable display)
- Display in volume or mass dimensions
- Density as constant input value for conversion of volume into mass dimensions
- Forward/backward measurement
- Flow direction
- Diagnostics functions and control values
- Functions of the PROFIBUS PA output:
 - flow, net quantity (volume or mass), ultrasonic velocity, ultrasonic amplitude, forward quantity (volume or mass), backward quantity (volume or mass)
- Functions of the analog output:
 - flow, ultrasonic velocity or ultrasonic amplitude
- Functions of digital output 1:
 - pulse output, frequency output, limit, flow direction or device status
- Functions of digital output 2:
 - limit, flow direction or device status
- Simulation of output signal via analog output, digital output 1 and digital output 2

The HART protocol is implemented via the analog output (current output). Using this communication facility, the device can be parameterized with a PC/laptop and SIMATIC PDM software in addition to local operation.

In the version with PROFIBUS PA, the analog output is replaced by the digital PROFIBUS PA output. The device can then be parameterized via PROFIBUS communication and with SIMATIC PDM in addition to local operation.

Technical specifications

Input	
Measurement	Flow by measuring the transit time difference of ultrasonic signals through ultrasonic transducers in DN 100 (4") ... 3000 (120") 2-path sensor pipes (depending on selected size, 1-path or 4-path special solutions are possible).
Nominal diameters and number of paths	2-path DN 100 (4") ... DN 3000 (120") (depending on size, optionally also 1-path and 4-path)
Max. cable length	120 m (395 ft) (shielded coaxial cable). For Ex version the transducer cable length is restricted to 3 m (9.84 ft) in order to meet requirements for electrical immunity. For systems with sizes \geq DN 1500 (60") cable length is recommended to be max. 30 m (98.4 ft).
Analog output	
Function	Current output programmable for flow, sound velocity or amplitude level. Active current output (13.2 V < open loop voltage < 15.8 V) 4 ... 20 mA 20 ... 22.5 mA, adjustable 3.6 mA, 22 mA, or 24 mA Max. 600 Ω ; for non Ex version \geq 230 Ω for HART communication \leq 330 Ω for Ex-version
<ul style="list-style-type: none"> • Signal range • Upper limit • Signal on alarm • Load 	
• Only PROFIBUS PA version:	Analog output omitted, is replaced by digital PROFIBUS PA interface
Digital output 1	
Function	Pulse, frequency or status output - programmable for pulses, frequency, alarm, limit or status.
<ul style="list-style-type: none"> • Active or passive signal, can be configured with positive or negative logic 	Active: 24 V DC, \leq 24 mA, $R_i = 300 \Omega$ Passive: open collector, 30 V DC, \leq 200 mA
<ul style="list-style-type: none"> • For explosion protection (ATEX version) and PROFIBUS PA version 	Only passive: open collector 30 V DC, \leq 100 mA
<ul style="list-style-type: none"> • Output function, configurable 	Pulse output <ul style="list-style-type: none"> • Adjustable pulse significance \leq 5000 pulses/s • Adjustable pulse width \geq 0.1 ms Frequency response <ul style="list-style-type: none"> • f_{END} selectable up to 10 kHz Limit for flow, totalizers, ultrasonic velocity or ultrasonic amplitude device status, flow direction

Flow Measurement

SITRANS F US Inline

Transmitter SITRANS FUS060

<p>Digital output 2</p> <p>Function</p> <ul style="list-style-type: none"> Relay, NC or NO contact For explosion protection (ATEX version) Output function, configurable Only PROFIBUS PA version: 	<p>Relay output - programmable for alarm, limit or status indication. Switching capacity max. 5 W Max. 50 V DC, max. 200 mA DC Self-resetting fuse, $R_i = 9 \Omega$</p> <p>Max. 30 V DC, max. 100 mA DC, 50 mA AC (cf. EC-Type Examination certificate)</p> <p>Limit for flow, ultrasonic velocity or ultrasonic amplitude flow direction device status</p> <p>Digital output 2 omitted</p>	<p>Rated operation conditions</p> <p><u>Ambient conditions</u></p> <p>Ambient temperature</p> <ul style="list-style-type: none"> Operation In potentially explosive atmospheres Storage <p>Enclosure rating</p> <p>Electromagnetic compatibility</p> <ul style="list-style-type: none"> Emitted interference Noise immunity <p><u>Medium conditions</u></p> <ul style="list-style-type: none"> Process temperature Gases/solids 	<p>-20 ... +50 °C (-4 ... +122 °F)</p> <p>Observe temperature classes</p> <p>-25 ... +80 °C (-13 ... +176 °F)</p> <p>IP65 (NEMA 4)</p> <p>For use in industrial environments</p> <p>To EN 55011/CISPR-11</p> <p>To EN/IEC 61326-1 (Industry)</p> <p>The measuring media must be ultrasonic signal compatible. It must be homogeneous and not two-phased to transfer the acoustic ultrasonic signals.</p> <p>-200 ... +250 °C (-328 ... +482 °F) (not directly influenced by medium temperature)</p> <p>Influence accuracy of measurement (approx. max. 3 % gases or solids)</p>
<p>Communication via analog output 4 ... 20 mA</p> <ul style="list-style-type: none"> PC/laptop or HART communicator with SITRANS F flowmeter Load with connection of coupling module Load with connection of HART communicator Cable Protocol 	<p>min. 230 Ω (max. 330 Ω for Ex-version)</p> <p>min. 230 Ω</p> <p>2-wire shielded ≤ 3 km (≤ 1.86 miles)</p> <p>Multi-core shielded ≤ 1.5 km (≤ 0.93 miles)</p> <p>HART, version 5.1</p>	<p>Design</p> <p>Separate version</p> <p>Enclosure material</p> <p>Wall mounting bracket (standard and special)</p> <p>Weight of transmitter</p> <p>Electrical connection</p>	<p>Transmitter is connected to the transducers via 3 ... 120 m (9.8 ... 395 ft) long specially shielded cables (coaxial cable)</p> <p>For ATEX versions mounted in the Ex area only with 3 m (9.8 ft) long cables.</p> <p>Die-cast aluminum, painted</p> <p>Stainless steel (standard: always incl.)</p> <p>4.4 kg (9.7 lb)</p> <p>Cable glands (always incl.)</p> <ul style="list-style-type: none"> Power supply and outputs <ul style="list-style-type: none"> 2 x M20 (HART)/M25 (PROFIBUS) or 2 x 1/2" NPT (HART) Transducers/sensor <ul style="list-style-type: none"> 2/4 x M16 or 2/4 x 1/2" NPT
<p>Communication via PROFIBUS PA interface</p> <ul style="list-style-type: none"> Power supply Current consumption from bus 	<p>Layers 1 + 2 according to PROFIBUS PA Communication system according to IEC 61158/EN 50170</p> <p>Separate supply, four-wire device Permissible bus voltage 9 ... 32 V See certificates and approvals</p> <p>10 mA; ≤ 15 mA in event of error with electronic current limiting</p>	<p>Displays and controls</p> <p>Display</p> <ul style="list-style-type: none"> Multi-display: 2 freely-selectable values are displayed simultaneously in two lines <p>Operation</p>	<p>LCD, two lines with 16 characters each</p> <p>Flow, volume, mass flow, mass, flow velocity, speed of sound, ultrasonic signal information, current, frequency, alarm information</p> <p>4 infrared keys, hierarchical menu shown with codes</p>
<p>Electrical isolation</p>	<p>Outputs electrically isolated from power supply and from one another</p>	<p>Power supply</p> <p>Supply voltage</p> <ul style="list-style-type: none"> Standard version Ex version <p>Power failure</p> <p>Power consumption</p>	<p>120 ... 230 V AC ± 15 % (50/60 Hz) or 19 ... 30 V DC/21 ... 26 V AC</p> <p>19 ... 30 V DC/21 ... 26 V AC</p> <p>No effect for at least 1 period (> 20 ms)</p> <p>Approx. 10 VA/10 W</p>
<p>Accuracy</p> <p>Error in measurement (at reference conditions)</p> <ul style="list-style-type: none"> Pulse output Analog output 4 ... 20 mA Repeatability <p>Reference conditions (water)</p> <ul style="list-style-type: none"> Process temperature in the connected sensor Ambient temperature at the transmitter Transmitter warming-up time <p>Installation conditions of connected sensor</p>	<p>Outputs electrically isolated from power supply and from one another</p> <p>$\leq \pm 0.5$ % of measured value at 0.5 ... 10 m/s or $\leq \pm 0.25\sqrt{V}$ [m/s] % of measured value at flow < 0.5 m/s</p> <p>As pulse output plus ± 0.1 % of measured value, $\pm 20 \mu\text{A}$</p> <p>$\leq \pm 0.25$ % of measured value at 0.5 ... 10 m/s</p> <p>25 °C ± 5 °C (77 °F ± 9 °F)</p> <p>25 °C ± 5 °C (77 °F ± 9 °F)</p> <p>30 min.</p> <p>Upstream section $> 10 \times$ DN and downstream section $> 5 \times$ DN</p>	<p>Certificates and approvals</p> <p>Explosion protection</p>	<p>ATEX II 2 G Ex dem [ia/ib] IIC T6/T4/T3 Gb</p> <p>T6 for media < 85 °C (185 °F)</p> <p>T5 for media < 100 °C (212 °F)</p> <p>T4 for media < 135 °C (275 °F)</p> <p>T3 for media < 200 °C (392 °F)</p>

Coaxial cable

Standard Coaxial cable (75 Ω)

Coaxial cable with SMB straight plug on one end for connection to the FUS060

Pre-terminated, can be shortened on sensor side



Outside diameter	Ø 5.8 mm
Length	3, 15, 30, 60, 90, 120 m (9.84, 49.21, 98.43, 196.85, 295.28, 393.70 ft) between sensor and transmitter
Material (outside jacket)	black PE
Ambient temperature	-10 ... +70 °C (14 ... 158 °F)

High temperature Coaxial cable (75 Ω)

Coaxial cable with SMB straight plug on one end for the connection to FUS060

Fix terminated, can NOT be shortened

Outside diameter	Ø 5.13 mm (first 0.3 m (0.98 ft) part to the transducer), Ø 5.8 mm (for remaining cable to the transmitter - with SMB plug at the end) and between these is a black hot melt junction Ø 16 mm (length 70 mm)
Length	3, 15, 30 m (9.84, 49.21, 98.43 ft) between sensor and transmitter (max 3 m 9.84 ft) transducer cable length for Ex area mounted transmitters)

Material (outside jacket)	Brown PTFE (0.3 m (0.98 ft) part) and black PE (for remaining cable)
Ambient temperature	-200 ... +200 °C (-328 ... +392 °F) (brown PTFE transducer part) and -10 ... +70 °C (14 ... 158 °F) (black PE for remaining transmitter cable part)

Dimensional drawings

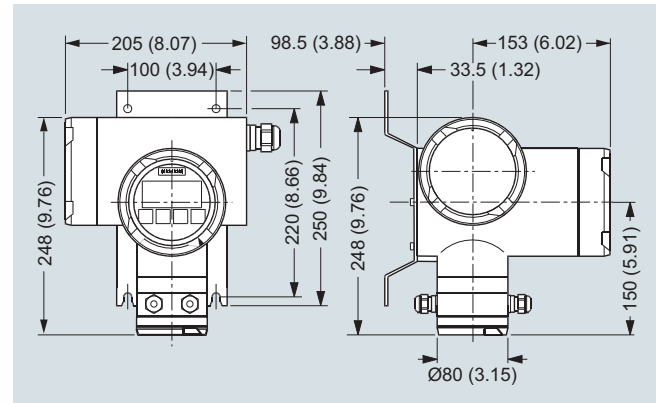

SITRANS FUS060 with standard mounting bracket, dimensions in mm (inch)

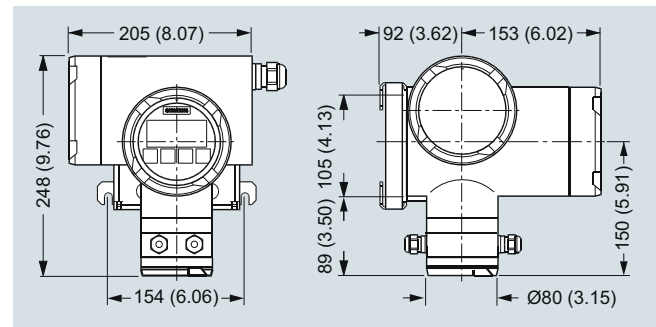

SITRANS FUS060 with optional special mounting bracket, dimensions in mm (inch)

Schematics

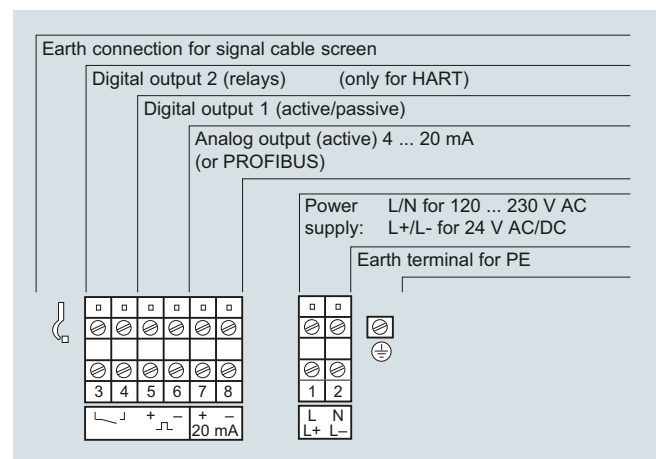

Electrical connection SITRANS FUS060

Flow Measurement

SITRANS F US Inline

Transmitter SITRANS FUS060



Transmitter FUS060 operating instructions, accessories and spare parts

Operating instructions

Description	Article No.
• English	A5E01204521
• German	A5E02123845

All literature is available to download for free, in a range of languages, at www.siemens.com/processinstrumentation/documentation

Accessories

Description	Article No.	
Standard wall mounting bracket	7ME5933-0AC04	
Special wall-/pipe mounting bracket kit	7ME5933-0AC05	
Safety clamp for electronic cover with glass plate (7ME5933-0AC01)	7ME5933-0AC06	

Process Device Manager SIMATIC PDM

SIMATIC PDM
Details about the SIMATIC PDM tool can be found on page 8/5, chapter "Communication and Software"

See page 8/13, chapter "Communication and Software"



HART modem for communication with FUS060 HART, PC and SIMATIC PDM

HART modem
With USB connection

7MF4997-1DB













Spare parts

SITRANS FUS060 transmitter, available standard and Ex versions

The transmitter configuration is made in the flowmeter Order codes (together with the sensors). The information below is for spare part ordering only and with fixed standardized pre-settings for a DN 2000 2-path system.

Description	Version	Enclosure	Supply	Article No.	
FUS060, 230 V, HART, Metric cable glands	Transmitter for remote connection	IP65 (NEMA 4)	115 ... 230 V AC 50/60 Hz	7ME3050-2BA10-1BA1	
FUS060, 230 V, HART, Imperial cable glands	Transmitter for remote connection	IP65 (NEMA 4)	115 ... 230 V AC 50/60 Hz	7ME3050-2BA10-1BA2	
FUS060, 230 V, PROFIBUS, Metric cable glands	Transmitter for remote connection	IP65 (NEMA 4)	115 ... 230 V AC 50/60 Hz	7ME3050-2BA10-1DA1	
FUS060, 230 V, PROFIBUS, Imperial cable glands	Transmitter for remote connection	IP65 (NEMA 4)	115 ... 230 V AC 50/60 Hz	7ME3050-2BA10-1DA2	
FUS060, 24 V, HART, Metric cable glands	Transmitter for remote connection	IP65 (NEMA 4)	19 ... 30 V DC/ 21 ... 26 V AC	7ME3050-2BA20-1BA1	
FUS060, 24 V, HART, Imperial cable glands	Transmitter for remote connection	IP65 (NEMA 4)	19 ... 30 V DC/ 21 ... 26 V AC	7ME3050-2BA20-1BA2	
FUS060, 24 V, PROFIBUS, Metric cable glands	Transmitter for remote connection	IP65 (NEMA 4)	19 ... 30 V DC/ 21 ... 26 V AC	7ME3050-2BA20-1DA1	
FUS060, 24 V, PROFIBUS, Imperial cable glands	Transmitter for remote connection	IP65 (NEMA 4)	19 ... 30 V DC/ 21 ... 26 V AC	7ME3050-2BA20-1DA2	
FUS060, ATEX, 24 V, HART, Metric cable glands	Transmitter for remote connection	IP65 (NEMA 4) ATEX approval	19 ... 30 V DC/ 21 ... 26 V AC	7ME3050-2BA21-1CA1	

Ordering of pre-configured FUS060 spare transmitters only via PVR (product variation request - special request)

Description	Article No.		Description	Article No.	
Operating/Display module	7ME5933-0AC00		M20 cable gland set for FUS060 ATEX version power and output connection, PA plastic, 1 x in blue (ATEX Ex i) and 1 x gray (ATEX Ex-e) • cables Ø 5 ... 9 mm (0.20" ... 0.35") • -20 ... +95 °C (-4 ... +203 °F)	A5E02246356	
Electronics cover with glass plate (non Ex) . Die cast aluminum, with corrosion-resistant Basic Polyester powder coating (min. 60 µm)	7ME5933-0AC01		1/2" NPT cable gland set for FUS060 (NPT) power and output connection, gray PA plastic, 2 pcs. • cables Ø 6 ... 12 mm (0.24" ... 0.47") • -40 ... +100 °C (-40 ... +212 °F)	A5E02246396	
Cover for sensor cable and gasket. Die cast aluminum, with corrosion-resistant Basic Polyester powder coating (min. 60 µm)	7ME5933-0AC02		M25 cable gland set for the FUS060 PA (M25) power and output connection, gray PA plastic, 2 pcs. • cables Ø 9 ... 16 mm (0.35" ... 0.63") • -40 ... +100 °C (-40 ... +212 °F)	A5E02246378	
Cover for mains supply/communication. Die cast aluminum, with corrosion-resistant Basic Polyester powder coating (min. 60 µm)	7ME5933-0AC03		M16x1.5 cable gland set for FUS060 (M16) sensor connection, gray PA plastic, 2 pcs. and 2 pcs. blind. • cables Ø 5 ... 9 mm (0.20" ... 0.35") • -40 ... +100 °C (-40 ... +212 °F)	A5E02593526	
FUS060 Sensor connection PCBA, Standard versions only, 1 pc.	A5E02551331		M16 x 1.5 cable gland set for FUS060 (M16) sensor connection, brass chrome, 2 pcs. and 2 pcs. blind • cables Ø 5 ... 9 mm (0.20" ... 0.35") • -20 ... +105 °C (-4 ... +221 °F)	A5E02246369	
FUS060 Sensor connection PCBA, ATEX version only, 1 pc.	A5E02551334		1/2" NPT cable gland set for FUS060 (NPT) sensor connection, 4 pcs. M16 bush to 1/2" NPT and 4 pcs. 1/2" NPT gray PA plastic glands • cables Ø 5 ... 9 mm (0.20 ... 0.35") • -20 ... +100 °C (-4 ... +212°F)	A5E02247877	
M20 cable gland set for FUS060 (M20) power and output connection, gray PA plastic, 2 pcs. • cables Ø 6 ... 12 mm (0.24" ... 0.47") • -40 ... +100 °C (-40 ... +212 °F)	A5E02246350				

Flow Measurement

SITRANS F US Inline

Transmitter SITRANS FUS060

Cables for FUS060

Description	Length m (ft)	Article No.
Coaxial cable for FUS060, (75 Ω, max. 70 °C (158 °F), black PVC) (2 pcs.)	3 (9.84)	A5E00875101
	15 (49.21)	A5E00861432
	30 (98.43)	A5E01278662
	60 (196.85)	A5E01278682
	90 (295.28)	A5E01278687
	120 (393.70)	A5E01278698
High temp. coaxial cable for FUS060; with 0.3 m brown PTFE high temp. transducer part, max. 200 °C (392 °F) and black PVC for remaining transmitter part with SMB plug, max. 70 °C (158 °F), impedance 75 Ω (2 pcs.)	3 (9.84)	A5E00875105
	15 (49.21)	A5E00861435
	30 (98.43)	A5E01196952
Special coaxial cable sets for low temperature cryogenic systems; with SMB plug for transmitter SITRANS FUS060, PTFE material, temp. -200 ... +200 °C (-328 ... +392 °F), impedance 75 Ω (2 pcs.)	10 (32.84)	A5E02085593
	15 (49.21)	A5E03262088
	30 (98.43)	A5E02085644
	40 (131.23)	A5E02085649

