



OPTIBAR PSM 1010 **Technical Datasheet**

Electronic pressure switch with recessed diaphragm for general application

1	Product features	3
<hr/>		
1.1	Universal pressure switch for general application	3
2	Technical data	5
<hr/>		
2.1	Technical data.....	5
2.2	Dimensions	8
3	Installation	11
<hr/>		
3.1	General notes on installation	11
3.2	Installation specifications	11
3.3	Mounting	12
3.3.1	Installation steps for connections acc. to DIN 3852.....	12
3.3.2	Installation steps for connections acc. to EN 837	13
3.3.3	Installation steps for NPT connections	13
4	Electrical connections	14
<hr/>		
4.1	Safety instructions.....	14
4.2	Terminal assignment	14
4.3	Electrical connection diagrams	15
4.4	Switching output signals	15
5	Order code	19
<hr/>		
6	Notes	21
<hr/>		

1.1 Universal pressure switch for general application

The **OPTIBAR PSM 1010** pressure switch is universally used for general purpose application in the field of industrial measuring technology. The 1.4435 / AISI 316L diaphragm brings good corrosion resistance in many industrial processes.

The pressure switch features an IO-Link-interface by default to exchange process data, diagnosis and status reports to a superordinate control level and to enable remote adjustment of the pressure switch.

For higher comfort and adjustment probabilities the OPTIBAR PSM 1010 provides an integrated display module. Via the VDMA-conform menu-structure in combination with the two push buttons the device can be configured on site. Since the display module is almost continuously rotatable, a perfect readability is always guaranteed.

The OPTIBAR PSM 1010 comes with a M12 4-pole electrical plug and offers two output signals at the same time with multiple communications like 4...20 mA, 0...10V, NPN and PNP switches, as well as IO-Link. This enables the use as pressure switch and transmitter simultaneously.



Figure 1-1: OPTIBAR PSM 1010

- ① Display unit
- ② M12 x 1 4-pole electrical connection
- ③ Process connection with build-in pressure cell

Highlights

- Two configurable outputs independent from device configuration
- Additional diagnostics: Pressure peak and operating hours counter
- Multi-rotatable display and adjustment module
- Switching output PNP / NPN including window and hysteresis function
- Analog output 3-wire 0...10 V / 4...20mA with adjustable measuring range
- Full IO-Link integration according to specification V1.1
- Fully welded pressure measuring cell with 1.4435 / AISI 316L stainless steel diaphragm
- Measuring range: 0,1...600 bar / 4...8700 psi

Industries

- Plant construction and engineering
- Environmental technology
- Power generation
- Factory automation
- Hydraulic and pneumatic systems
- Pumps and compressors

Applications

- Absolute and gauge pressure measurement in gases and liquids
- Process automation
- Dry-run protection of delivery pumps
- Pressure monitoring of compressors

2.1 Technical data

- *The following data is provided for general applications. If you require data that is more relevant to your specific application, please contact us or your local sales office.*
- *Additional information (certificates, special tools, software,...) and complete product documentation can be downloaded free of charge from the website (Downloadcenter).*

Measuring system

Measuring principle	Piezoresistive measuring cell
Application range	Measurement of gauge and absolute pressure in gases and liquids
Measuring range	0.1...40 bar / 1.5...580 psi; refer also to chapter "Measuring ranges" Adjustment (in relation to the nominal range): Zero: $\pm 5\%$ Span: 90...100%

Display and user interface

Display on signal converter	4-digit, 7-segment LED-Display 22.5 x 10.5 mm / 0.89 x 0.41" 4 LED's for indication of unit (bar, mbar, PSI, Mpa) Status LED for IO-Link and switching-outputs Display infinitely rotatable up to -210° and $+100^\circ$ Ambient temperatures below -20°C may affect the readability of the display
Display function	Display of measured value All parameters are accessible via the operating menu
Operating	Local operation via 2 softkeys on the display and adjustment module
Remote control	IODD (e.g. PACTware™ via USB IO-Link interface)

Measuring accuracy

Reference conditions	Medium: air
	Temperature: ambient temperature
	Ambient pressure: 1013 mbar / 14.7 psi
	Nominal position: vertical, pressure port down
	Power supply: 24 VDC
Pressure type	Gauge pressure / absolute pressure
Measuring accuracy according to IEC 60770 (terminal based) (Hysteresis, non-linearity, non-repeatability)	Nominal pressure (P_N) < 0.4 bar / 5.8 psi: $\leq \pm 0.5\%$ of URL
	Nominal pressure (P_N) ≥ 0.4 bar / 5.8 psi: $\leq \pm 0.35\%$ of URL (URL = Upper Range Limit)
Ambient temperature effect on zero and span	$\leq \pm 0.3\%$ of URL per 10K in compensated range of $-25...85^\circ\text{C}$ / $-13...185^\circ\text{F}$
Long-term stability	$\leq \pm 0.3\%$ of URL within one year under reference conditions
Step response time	≤ 12 ms (T90)
Vacuum resistance	$P_N \geq 1$ bar / 14.5 psi: vacuum resistant $P_N < 1$ bar / 14.5 psi: on request

Operating conditions

Temperature	
Nominal temperature	-20...+85°C / -4...+185°F
Ambient temperature	-40...+85°C / -40...+185°F
Process temperature	-40...+100°C / -40...+212°F

Installation conditions

Mounting position	Any - factory calibration carried out with pressure port down.
Dimensions	For detailed information refer to chapter "Dimensions and weights".
Weight	Min. 230 g / 0.51 lb (depending on pressure port)

Materials

Housing	Stainless steel 1.4404 / AISI 316L
Fill fluid	Silicone oil
Wetted parts	
Pressure port	Stainless steel 1.4404 / AISI 316L
Separating diaphragm	Stainless steel 1.4435 / AISI 316L
Sealing	FKM, EPDM ($P_N \leq 160$ bar)

Process connections

Thread	Thread ANSI 1/2 NPT-Male, Thread ANSI 1/4 NPT-Male
	Thread ISO 228 G1/2"; DIN 3852, Thread ISO 228 G1/2"; EN 837-1, Thread ISO 228 G1/2" 10 mm bore; DIN 3852, Thread ISO 228 G1/4"; EN 837-1, Thread ISO 228 G1/4"; DIN 3852

Electrical connection

Output signal 1	IO-Link / SIO (PNP/NPN) switchable
Output signal 2	4...20 mA / 0...10 V (3-wire) / with PNP / NPN switchable
Power supply	$U_b = 18...30$ VDC
Load	4...20 mA / 3-wire: $R_{lmax} \leq (U_b - U_{bmin}) / 0.036$ A [Ohm] 0...10 V / 3-wire: $R_{lmin} \geq U_b / 0.0012$ A [Ohm]
Short circuit protection	Continuously
Reverse polarity protection	In the event of reversed connections there is no damage but also no function.
Ripple	Supply: 0.05% URL Load: $\leq 0.1\%$ URL
Electrical connection	Connector M12x1, 4-pin

Properties switching signal

Switch point accuracy	≤ +/- 0.5% URL
Repeatability	≤ +/- 0.1% URL
Max. switching current	150 mA
Switching frequency	max. 170 Hz
Delay	0...50 seconds

IO-Link

Interface	IO-Link 1.1; Slave
Data transmission	38.4 kbit/s (COM2)
Mode	SIO / IO-Link
Standard	IEC 61132-2, IEC 61161-9

Approvals and certificates

CE	The device fulfils the statutory requirements of the EU directives. The manufacturer certifies that these requirements have been met by applying the CE marking.
Electromagnetic compatibility (EMC) acc. to EN 61326-1:2013	EMC Directive: 2014/30/EU
	For more information consult the relevant declaration of conformity.
Pressure equipment directive	2014/68/EU
Other standards and approvals	
Protection category according to IEC 529 / EN 60529	IP67, NEMA 6
Vibration resistance acc. to EN 60068-2-6	10g RMS (25...2000 Hz)
Shock resistant (impact) according to EN 60068-2-27	500g / 11 ms (P _N ≥ 60 bar / 870 psi)

2.2 Dimensions

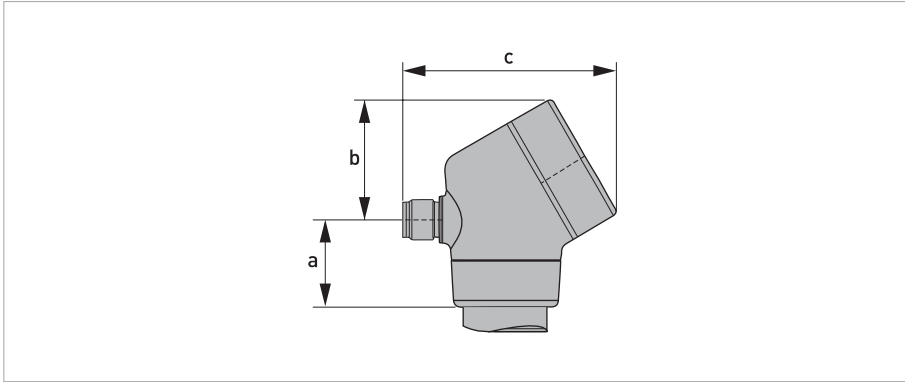

Figure 2-1: Dimensions

Dimensions					
a		b		c	
[mm]	["]	[mm]	["]	[mm]	["]
26	1.02	35.5	1.40	64	2.52

Table 2-1: Dimensions in mm and inch

Pressure transmitter with threaded connection (ISO 228)

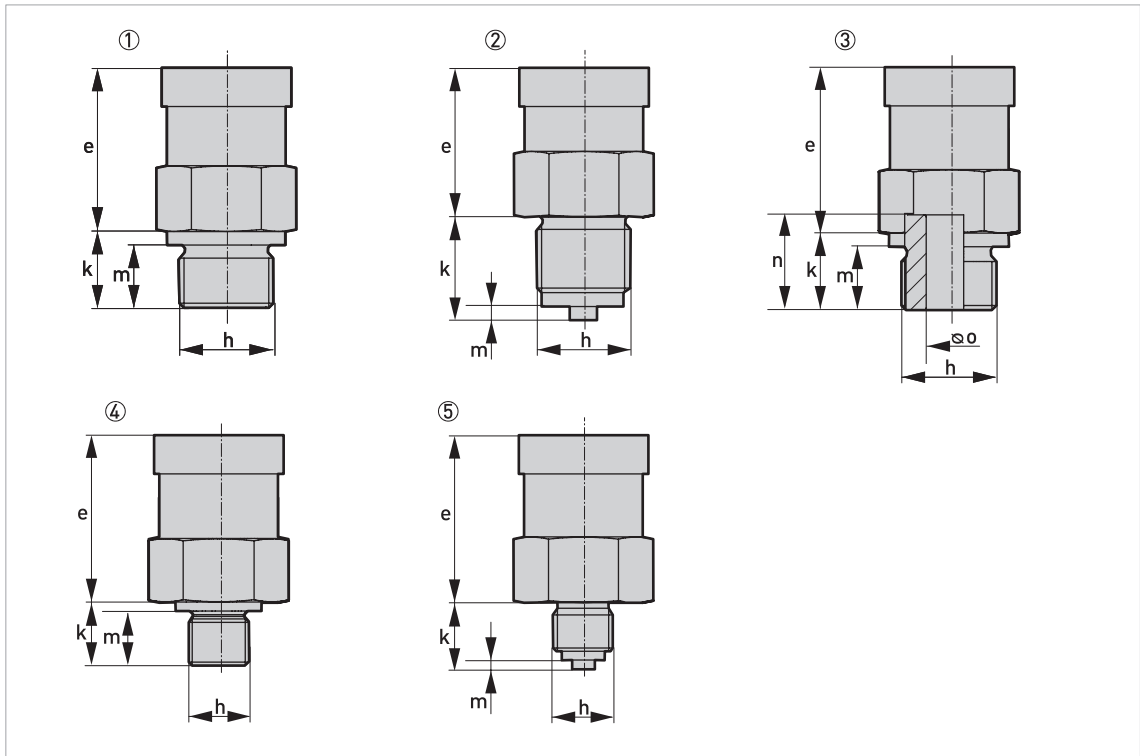

Figure 2-2: Dimensions for pressure transmitter with threaded connection (ISO 228)

- ① G1/2 DIN 3852
- ② G1/2 EN 837
- ③ G1/2 open connection (10 mm / 0.39" bore)
- ④ G1/4 DIN 3852
- ⑤ G1/4 EN 837

	Dimensions									
	①		②		③		④		⑤	
	[mm]	[""]	[mm]	[""]	[mm]	[""]	[mm]	[""]	[mm]	[""]
e*	50	2	50	2	50	2	50	2	50	2
h	G1/2		G1/2		G1/2		G1/4		G1/4	
k	17	0.67	23	0.9	17	0.67	14	0.55	15	0.59
m	14	0.55	3	0.12	14	0.55	12	0.47	2	0.08
n	-	-	-	-	21	0.83	-	-	-	-
o	-	-	-	-	Ø10	Ø0.39	-	-	-	-

Table 2-2: Dimensions for pressure transmitter with threaded connection (ISO 228)

* PN ≥ 60 bar: The length of the device increases by 9 mm

The total length of the device consists of the electrical connection (a), the transmitter housing (e) and the process connection (k).

Pressure transmitter with threaded connection (ANSI)

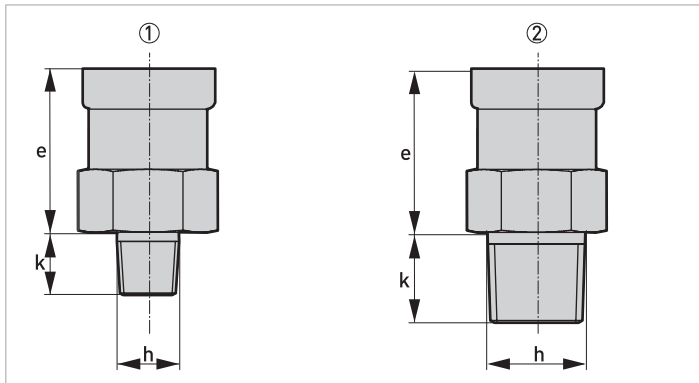

Figure 2-3: Dimensions for pressure transmitter with threaded connection (ANSI)

- ① Thread ANSI 1/4 NPT-M
- ② Thread ANSI 1/2 NPT-M

	Dimensions			
	①		②	
	[mm]	[""]	[mm]	[""]
e*	50	2	50	2
h	1/4 NPT		1/2 NPT	
k	14	0.55	20	0.79

Table 2-3: Dimensions for pressure transmitter with threaded connection (ANSI)

* PN ≥ 60 bar: The length of the device increases by 9 mm

The total length of the device consists of the electrical connection (a), the transmitter housing (e) and the process connection (k).

3.1 General notes on installation

Inspect the packaging carefully for damages or signs of rough handling. Report damage to the carrier and to the local office of the manufacturer.

Do a check of the packing list to make sure that you have all the elements given in the order.

Look at the device nameplate to ensure that the device is delivered according to your order. Check for the correct supply voltage printed on the nameplate.

3.2 Installation specifications

Install the device only when depressurised and without power!

For installation the respective regulations for explosion protection have to be fulfilled.

For installations outdoor and in damp areas, the following points must be observed:

- *To ensure that no moisture can get into the connector, the device should be connected electrically immediately after installation. Otherwise a moisture admission has to be prevented e.g. by using a suitable protection cap.*
- *Select an installation if possible, where a mounting position allows draining of spray and condensate. Sealing surfaces should not be submerged!*
- *When using devices with cable glands or output, the cable should be looped facing down so that any liquid that collects on the cable can drip off.*
- *Install the device so it is protected from direct sunlight. In the worst case scenario, the permissible operating temperature will be exceeded in the presence of direct sunlight. This can negatively affect or damage the functionality of the device. In addition, it can lead to temporary measuring errors if the internal pressure of the device increases due to the sunlight.*
- *When installing outside where the risk of lightning or overvoltage may exist and damage the device, we recommend installing suitable overvoltage protection between the supply device or control cabinet and the device.*

- *Handle this highly sensitive electronic measuring device with care, both in and out of the packaging!*
- *Only remove the packaging and any protection cap from the device immediately before installing to prevent damage to the diaphragm! Keep the supplied protection cap! Remove the protection cap slowly and carefully to avoid any negative pressure on the diaphragm.*
- *Handle the unprotected diaphragm with extreme care; it is very easily damaged.*
- *A device with a gauge reference in the housing (small hole next to the electrical connection) must be installed so that the gauge reference necessary for measurement is protected from dirt and moisture. Should the pressure transmitter be exposed to fluid admission, the air pressure compensation is blocked by the gauge reference. Accurate measurement in this state is not possible. It can also result in damage to the pressure transmitter.*
- *Ensure that no mechanical stress is applied to the pressure port during installation as this may result in a shift in the characteristic curve. This applies in particular to very small pressure ranges as well as to devices with plastic pressure ports.*
- *With hydraulic systems, arrange the device so that the pressure port faces up (venting).*

3.3 Mounting

Do not screw in using the housing! Tightening this way can cause damage to the rotary mechanism on the housing.

- *Prior to installing the transmitter, it is essential to verify whether the version of the device on hand completely fulfils the technical and safety requirements of the measuring point. This applies in particular to the measuring range, overpressure resistance, temperature, explosion protection and operating voltage.*
- *Check the materials used for the wetted parts (e.g. gasket, process connection, separating diaphragm etc.) for suitability as regards process compatibility.*
- *The device must not be heated by radiated heat (e.g. exposure to the sun) to an electronics housing surface temperature above the maximum permissible ambient temperature. If it is necessary to prevent damage from heat sources, a heat protection (e.g. sun shade) has to be installed.*

3.3.1 Installation steps for connections acc. to DIN 3852

- Make sure that the O-ring fits properly in the intended groove.
- Ensure that the raised face of the receiving part has a smooth surface.
- Screw the device into the thread by hand.
- Devices with wrench flats must be tightened with a wrench. For information on tightening torque refer to the following table.

Wrench size	Tightening torque [Nm]
Wrench size of steel	
G1/4	approx. 5
G1/2	approx. 10
G3/4	approx. 15
G1	approx. 20
G1 1/2	approx. 25
Wrench size of plastic	
All sizes	max. 3

Table 3-1: Tightening torques for devices with wrench flats

3.3.2 Installation steps for connections acc. to EN 837

- When sealing, use a suitable gasket that corresponds to the product and pressure to be measured (e.g. a copper gasket).
- Ensure that the raised face of the receiving part has a smooth surface.
- Screw the device into the thread by hand.
- Then tighten the device with the wrench.

Wrench size	Tightening torque [Nm]
G1/4	approx. 20
G1/2	approx. 50

Table 3-2: Tightening torques

3.3.3 Installation steps for NPT connections

- When sealing, use a suitable sealing agent that is compatible with the product (e.g. PTFE tape).
- Screw the device into the thread by hand.
- Then tighten the device with the wrench.

Wrench size	Tightening torque [Nm]
1/4 NPT	approx. 30
1/2 NPT	approx. 70

Table 3-3: Tightening torques

4.1 Safety instructions

*All work on the electrical connections may only be carried out with the power disconnected.
Take note of the voltage data on the nameplate!*

Observe the national regulations for electrical installations!

For devices used in hazardous areas, additional safety notes apply; please refer to the Ex documentation.

*Observe without fail the local occupational health and safety regulations.
Any work done on the electrical components of the measuring device may only be carried out by properly trained specialists.*

*Look at the device nameplate to ensure that the device is delivered according to your order.
Check for the correct supply voltage printed on the nameplate.*

4.2 Terminal assignment

Install the device only when depressurised and without power!

		
Electrical connections	Description	M12x1 (4-pin)
Supply +		1
Supply -		3
Signal 1	IO-Link / PNP / NPN switchable (SIO)	4
Signal 2	PNP / NPN / mA / V switchable	2
Shielding		Pressure-port

Table 4-1: Terminal assignment

4.3 Electrical connection diagrams

Configuration of switching output

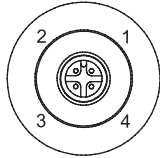
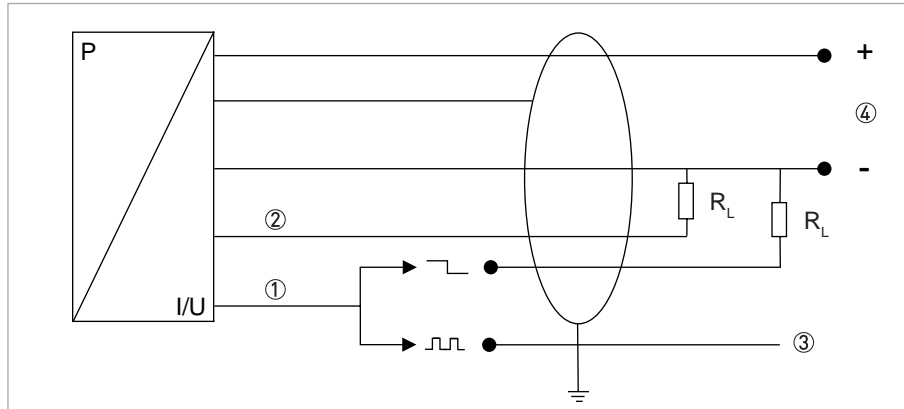

Figure 4-1: Electrical connection diagram 3-wire, contact output

- ① Signal 1
- ② Signal 2
- ③ IO-Link Master
- ④ Power supply

Configuration of analogue output

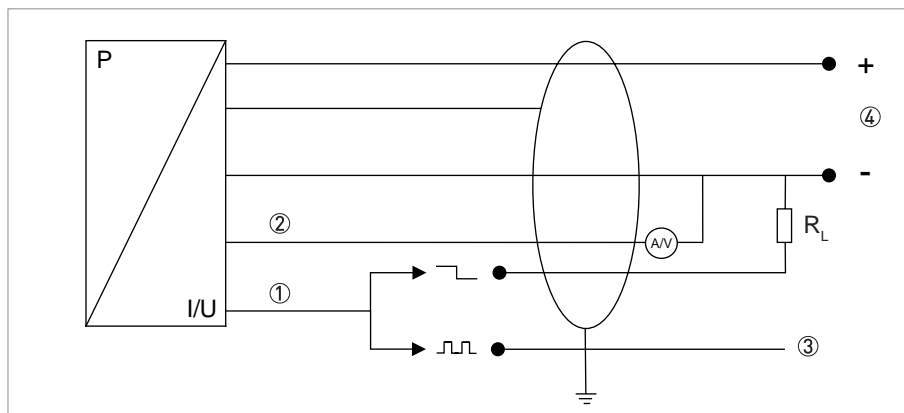

Figure 4-2: Electrical connection diagram 3-wire, analogue output

- ① Signal 1
- ② Signal 2
- ③ IO-Link Master
- ④ Power supply

4.4 Switching output signals

The output for the switching signals can be configured with two different function, both for normally open and normally closed actuators.

Window function

When the window function is activated, the output signal is set when the applied pressure is within the upper (FH) and lower (FL) pressure threshold:

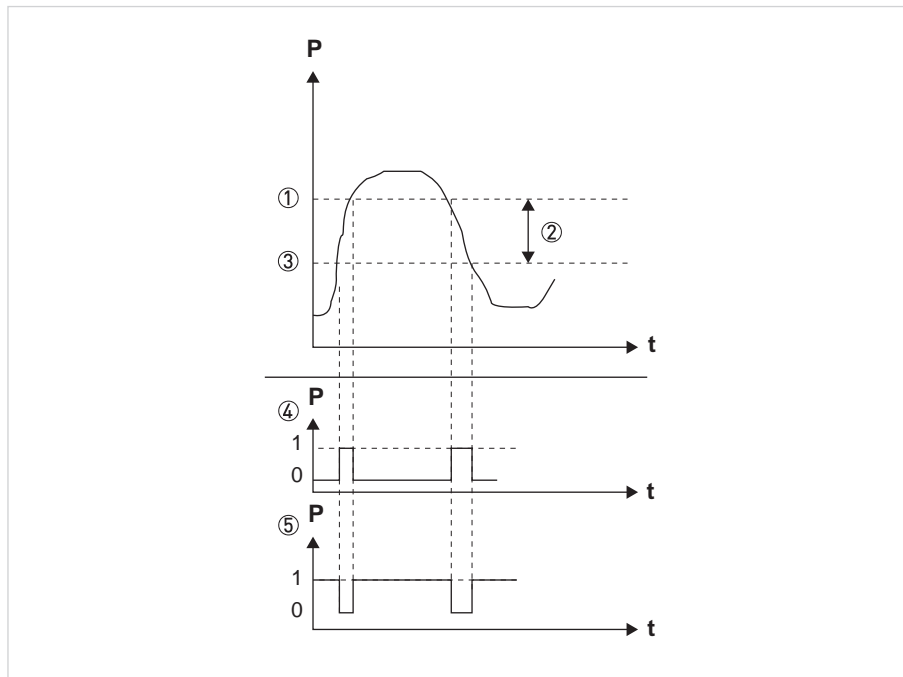

Figure 4-3: Switching output signals (window function)

- ① FH (window high)
- ② Pressure range
- ③ FL (window low)
- ④ Hno (normally open)
- ⑤ Hnc (normally closed)

Hysteresis-function

When the hysteresis-function is activated, the output signal is activated when the pressure reaches the switching pressure (SP) and deactivated when the release pressure (rP) is applied:

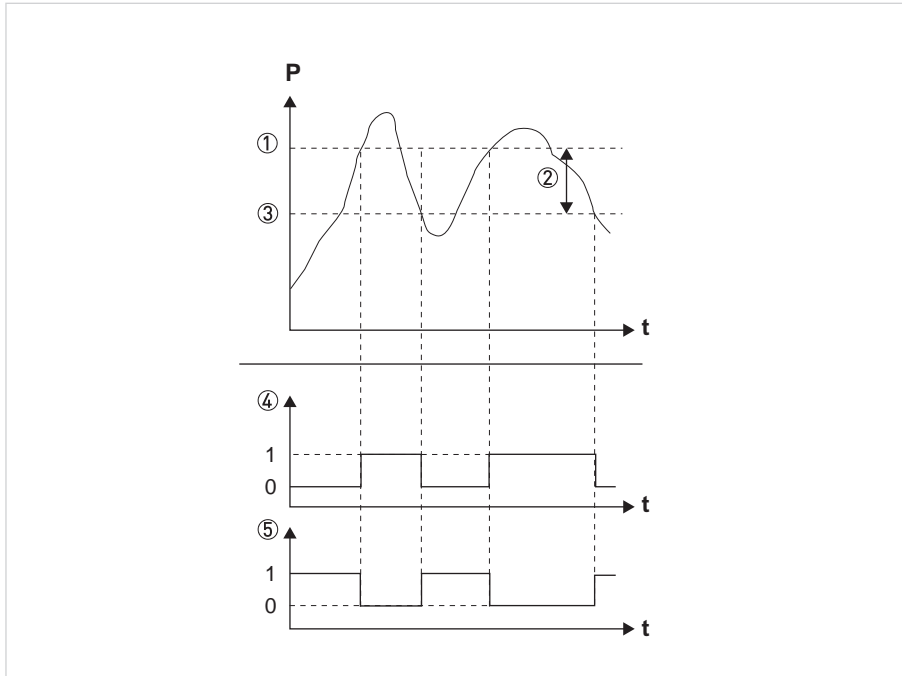

Figure 4-4: Switching output signals (hysteresis-function)

- ① SP (switch-on point)
- ② Hysteresis
- ③ rP (release point)
- ④ Hno (normally open)
- ⑤ Hnc (normally closed)

Hysteresis-function

To eliminate an unintended switching signal caused by pressure spikes, a damping-constant (dr, dS) can be configured for both switching-functions:

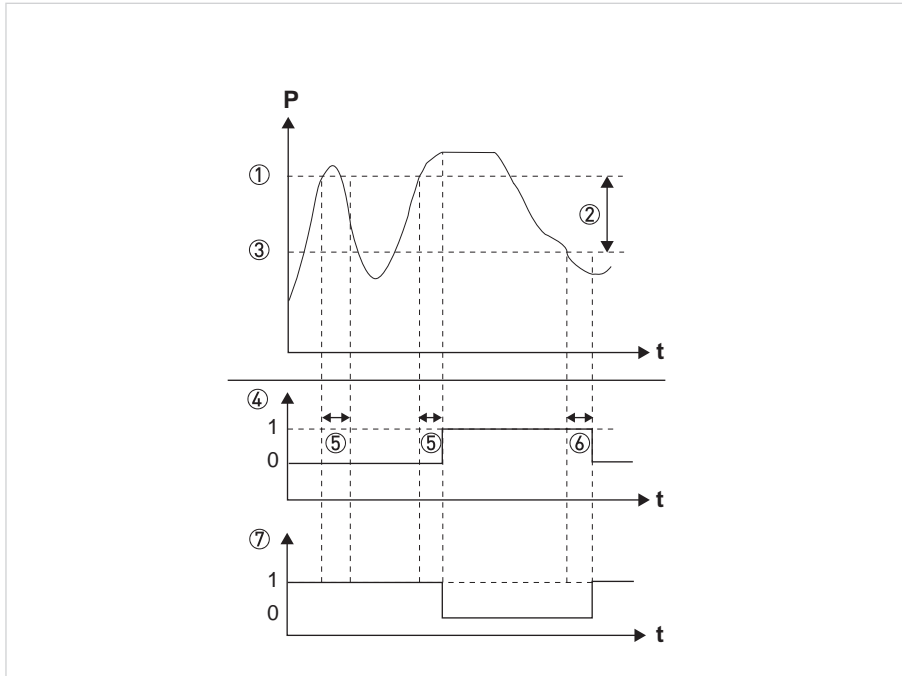

Figure 4-5: Switching output signals (hysteresis-function with damping)

- ① SP (switch-on point)
- ② Hysteresis
- ③ rP (release point)
- ④ Hnc (normally closed)
- ⑤ dS (delay switch-on)
- ⑥ dr (delay release)
- ⑦ Hno (normally open)

The characters of the order code highlighted in light grey describe the standard.

Sensor	Type			
VGKU	4	A Absolute Pressure		
		R Gauge Pressure		
		N Gauge Pressure with neg. nominal measuring range [-x...+x]		
			Measuring Range	MWP (Max. Working Pressure)
		1	100 mbar / 10 kPa / 1.5 psi	500 mbar / 50 kPa / 7.5 psi (only type N, R)
		2	160 mbar / 16 kPa / 2.3 psi	1 bar / 100 kPa / 14.5 psi (only type N, R)
		4	250 mbar / 25 kPa / 3.6 psi	1 bar / 100 kPa / 14.5 psi (only type N, R)
		5	400 mbar / 40 kPa / 5.8 psi	2 bar / 200 kPa / 29 psi
		6	500 mbar / 50 kPa / 7.5 psi	2 bar / 200 kPa / 29 psi
		7	600 mbar / 60 kPa / 8.7 psi	5 bar / 500 kPa / 72.5 psi
		A	1.0 bar / 100 kPa / 14.5 psi	5 bar / 500 kPa / 72.5 psi
		B	1.6 bar / 160 kPa / 23 psi	10 bar / 1 MPa / 145 psi
		C	2.0 bar / 200 kPa / 29 psi	10 bar / 1 MPa / 145 psi
		D	2.5 bar / 250 kPa / 36 psi	10 bar / 1 MPa / 145 psi
		E	4.0 bar / 400 kPa / 58 psi	20 bar / 2 MPa / 290 psi
		F	5.0 bar / 500 kPa / 72.5 psi	20 bar / 2 MPa / 290 psi
		G	6.0 bar / 600 kPa / 87 psi	40 bar / 4 MPa / 580 psi
		H	10 bar / 1 MPa / 145 psi	40 bar / 4 MPa / 580 psi
		K	16 bar / 1.6 MPa / 232 psi	80 bar / 8 MPa / 1160 psi
		M	25 bar / 2.5 MPa / 363 psi	80 bar / 8 MPa / 1160 psi
		N	40 bar / 4 MPa / 580 psi	100 bar / 10 MPa / 1450 psi
		R	60 bar / 6 MPa / 870 psi	200 bar / 20 MPa / 2900 psi (only type N, R)
		S	100 bar / 10 MPa / 1450 psi	200 bar / 60 MPa / 8702 psi (only type N, R)
		T	160 bar / 16 MPa / 2321 psi	600 bar / 60 MPa / 8702 psi (only type N, R)
		U	250 bar / 25 MPa / 3626 psi	1000 bar / 100 MPa / 14500 psi (only type N, R)
		V	400 bar / 40 MPa / 5802 psi	1000 bar / 100 MPa / 14500 psi (only type N, R)
		W	600 bar / 60 MPa / 8702 psi	1000 bar / 100 MPa / 14500 psi (only type N, R)
		Z	Custom measuring range	
			Process Connection / Material	
		0	Thread ANSI 1/2"NPT; 316L	
		1	Thread ISO228 G1/2"; DIN 3852; 316L	
		2	Thread ISO228 G1/2"; EN 837-1; 316L	
		3	Thread ISO228 G1/2" 10mm bore; DIN3852; 316L	
4	Thread ISO228 G1/4"; EN 837-1; 316L			
5	Thread ISO228 G1/4"; DIN3852; 316L			
6	Thread ANSI 1/4"NPT-Male; 316L			
Z	Custom process connection			
	Diaphragm / Fill Fluid			
S	316L (1.4435); Silicon oil			







